



使用说明书

GTC 电动油脂润滑泵

集中潤滑給油裝置
**CENTRALIZED
LUBRICATION
DEVICE**



专注减磨增效，成就客户核心竞争力

宝腾智能润滑技术(东莞)有限公司

BAOTN INTELLIGENT LUBRICATION TECHNOLOGY (DONGGUAN) CO.,LTD.







Directory

I、 Safety Instructions	1
II、 Declaration	1
III、 Overview	2
IV、 Lubrication Pump Dimensions & Working Principle	2
V、 Lubrication Pump Selection & Technical Specifications	3
VI、 Lubrication System Structure	4
VII、 Description of Quantitative Pressure-Type Distributor	5
VIII、 Quantitative Pressure-Release Grease Distributor	6
IX、 Progressive distributor	7
X、 Operating Instructions and Precautions	8
XI、 Troubleshooting and Solutions	11



I、 Safety Instructions

The following symbols provide important safety guidelines for proper product usage.	
	Read the product manual carefully before operation. Improper use may cause equipment damage or personal injury.
	Always disconnect power before performing maintenance or repairs.
	Ensure proper grounding during wiring. Incorrect grounding may cause severe damage
	Warning

II、 Declaration

All components are manufactured in compliance with occupational safety and accident prevention regulations. However, improper use may still pose risks to users, third parties, or property. Therefore, strictly follow the operating instructions. Any safety-related issues must be addressed immediately.

+ Disclaimer

Dongguan Baoteng is not liable for damages caused by:

Insufficient lubricant

Use of solid or incompatible lubricants

Improper usage

Installation or connection errors

Incorrect troubleshooting

+ Authorized Installation Technicians

Only certified engineers may install, operate, maintain, or repair this product. Certified personnel must be trained, experienced, and knowledgeable about relevant standards, regulations, and safety protocols.

+ Transport & Storage

No restrictions apply for road, air, or sea transport.

+ Environmental Protection

Oil and grease are hazardous to soil and water. Follow special safety regulations for storage, handling, and transportation.

III、 Overview

The GTC grease electric lubrication pump is specially designed and manufactured for various small and medium-sized machinery, offering high cost-effectiveness and practicality. It is suitable for CNC machinery, machining centers, production lines, as well as machinery in industries such as light textile, plastics, printing, chemical, woodworking, and food processing. It ensures the lubrication performance of various mechanical products, extends the service life of equipment, and maintains precision.

The GTC grease electric lubrication pump can be combined with quantitative volumetric distributors to form a volumetric lubrication system for quantitative lubrication of lubrication points. Especially when used with volumetric distributors such as GFA and GFD models produced by our company, it maximizes lubrication effectiveness. It can also be paired with proportional connectors like the GSA model to form a resistive (damping) lubrication system, providing proportional lubrication to each lubrication point.

IV、 Lubrication Pump Dimensions & Working Principle

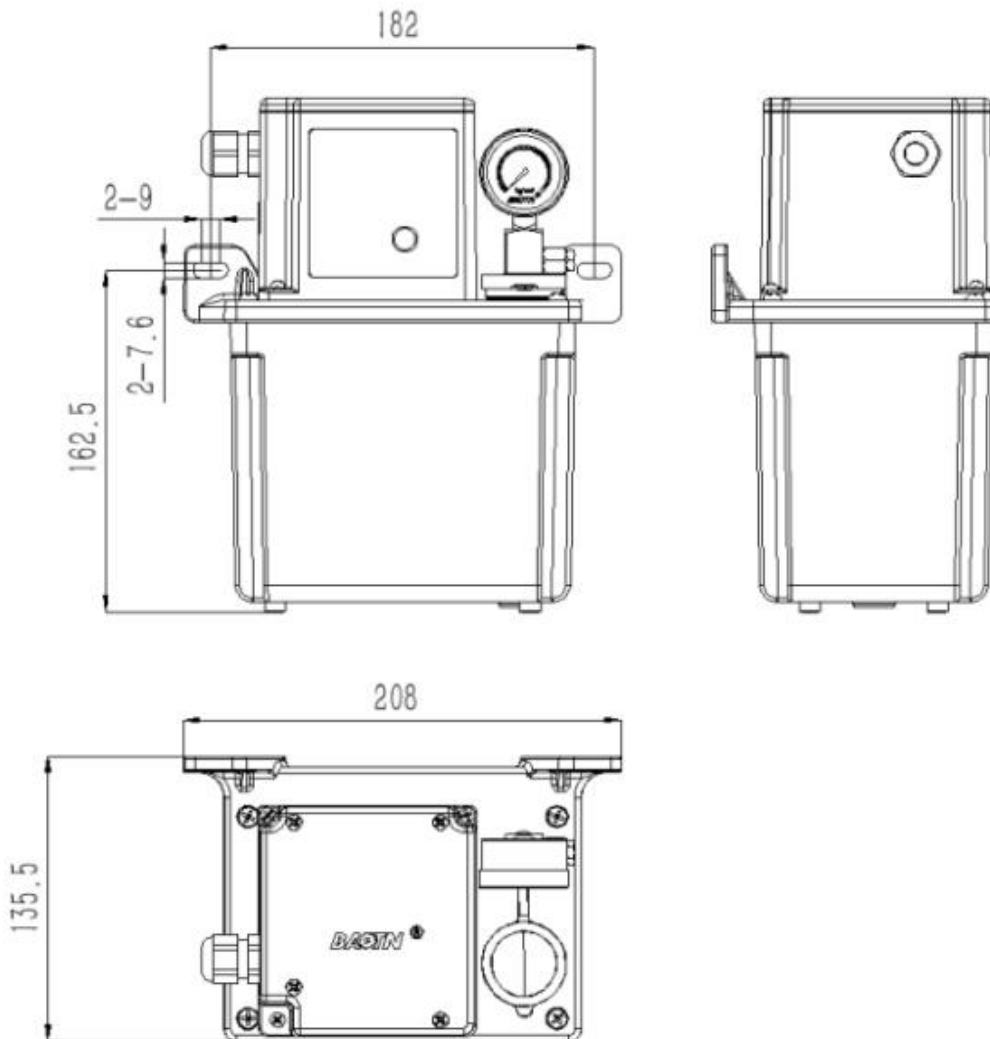

V、 Lubrication Pump Selection & Technical Specifications

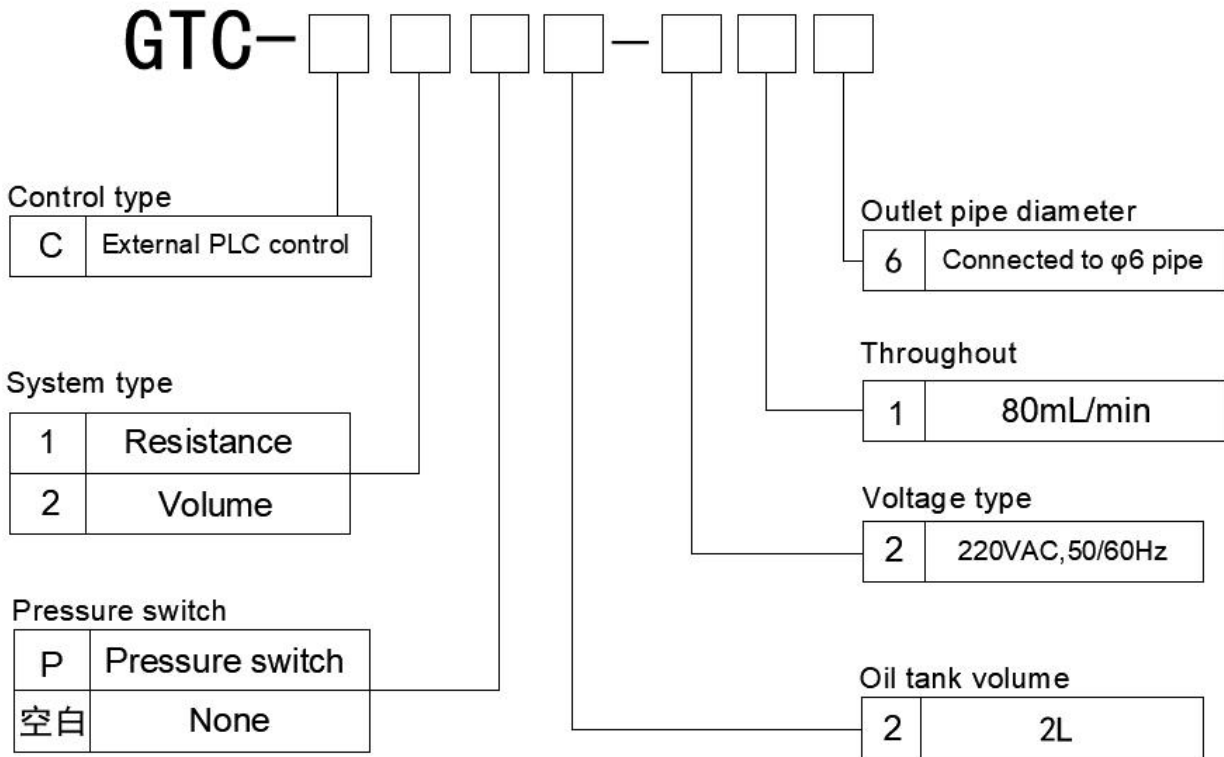

System Type:

- 1: Indicates resistive type (without a pressure relief device, used with a resistive distributor)
- 2: Indicates volumetric type (with a pressure relief device, used with a volumetric distributor)

Control Type:

- A: Digital display microcomputer controller
- C: Indicates external PLC control

type	Voltage (V)	Power (W)	Rated pressure (MPa)	最大压力 (MPa)	Throughout (mL/min)	Oil tank volume (L)	Oil viscosity	Applicable Temperature (°C)
GTC-C2	AC220	20	3	4	80	2	NLGI 000	0~50
GTC-C1			2					

VI、 Lubrication System Structure

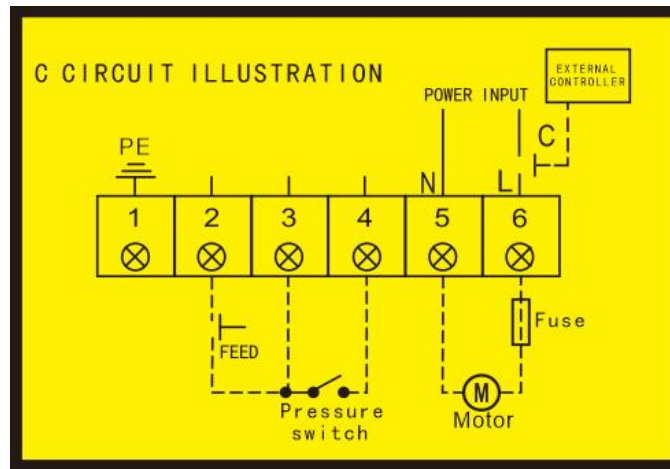

C Circuit Diagram

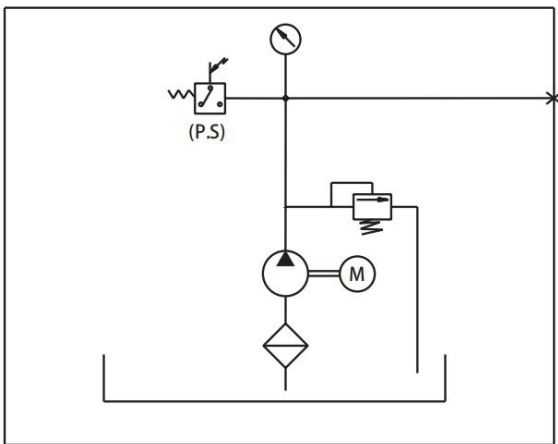

Resistance-type Schematic diagram

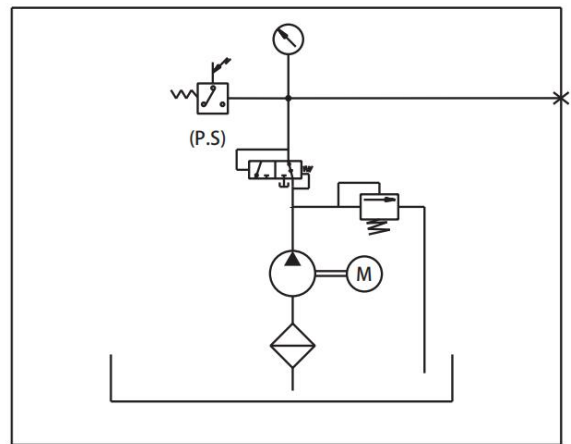

Volumetric centralized Schematic diagram

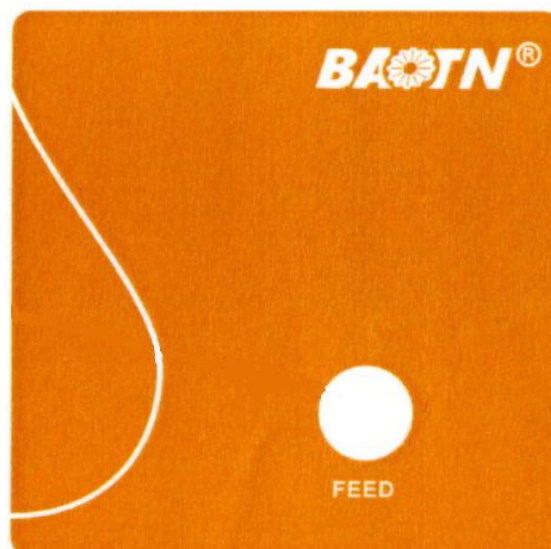

Type C Panel Sticker

VII、Description of Quantitative Pressure-Type Distributor

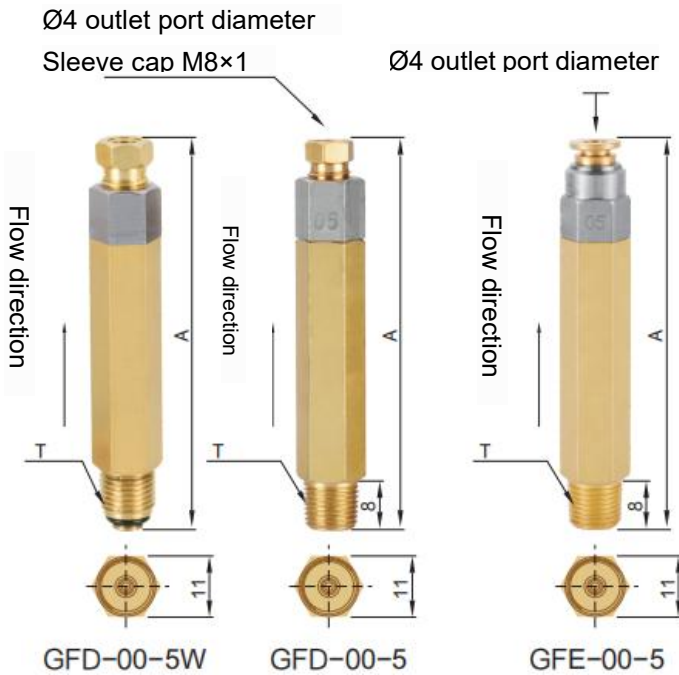

Order Coding Instructions

GFD/GFE-00 - [] []

Outlet Flow Rate Value

05	0.05 mL/次
1	0.1 mL/次
2	0.2 mL/次
3	0.3 mL/次
4	0.4 mL/次
5	0.5 mL/次

Thread Type

Blank	PT 1/8
W	M10×1

Model Specification	Discharge Volume	A	Marking	T	Weight (g)
GFD/GFE-00-05	0.05	53	00	PT	38
GFD/GFE-00-1	0.1	53	01		38
GFD/GFE-00-2	0.2	60	02	1/8	38
GFD/GFE-00-3	0.3	60	03	M10 ×1	38
GFD/GFE-00-4	0.4	71	04		54
GFD/GFE-00-5	0.5	71	05		54

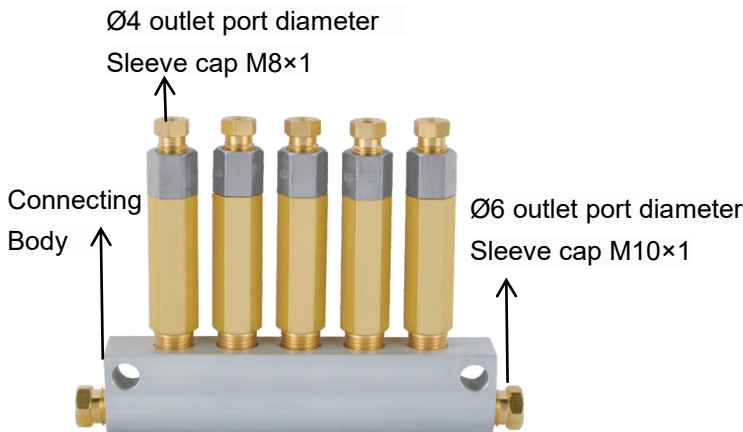

Product Outline Dimension Drawing

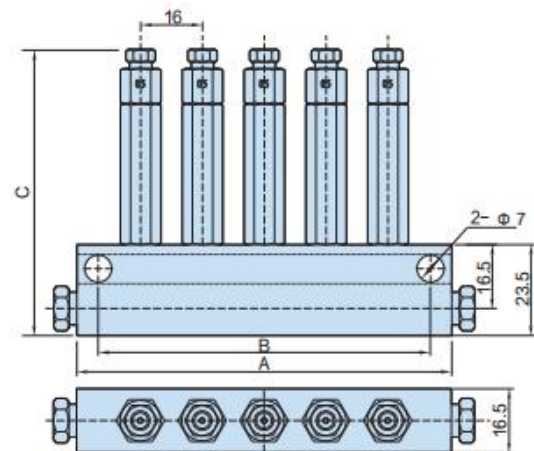

GFD/GFE- [] - [] - [] []

Number of Outlet Ports

Flow Rate Code

05	0.05mL
1	0.1mL
2	0.2mL
3	0.3mL
4	0.4mL
5	0.5mL

Inlet Port Type

blank	Pipe Fitting
K	Body thread PT 1/8

Number of Inlet Ports

blank	Dual Inlet Ports
S	Single Inlet Port

Notes:

1.Oil Output Representation Method:

① Uniform Output: When all outlet ports have the same flow rate, use a single value.

Example:GFD/GFE-05-2indicates all 5 outlets of the GFD/GFE distributor deliver 0.2 mL/cycle.

② Varied Output:For mixed flow rates, list values sequentially.Example:GFD/GFE-05-53235denotes outlet flows as 0.5/0.3/0.2/0.3/0.5 mL/cycle (ports 1–5 respectively).

2.Inlet Port Thread Options:

Available in M10×1 or PT1/8. Contact us for details.

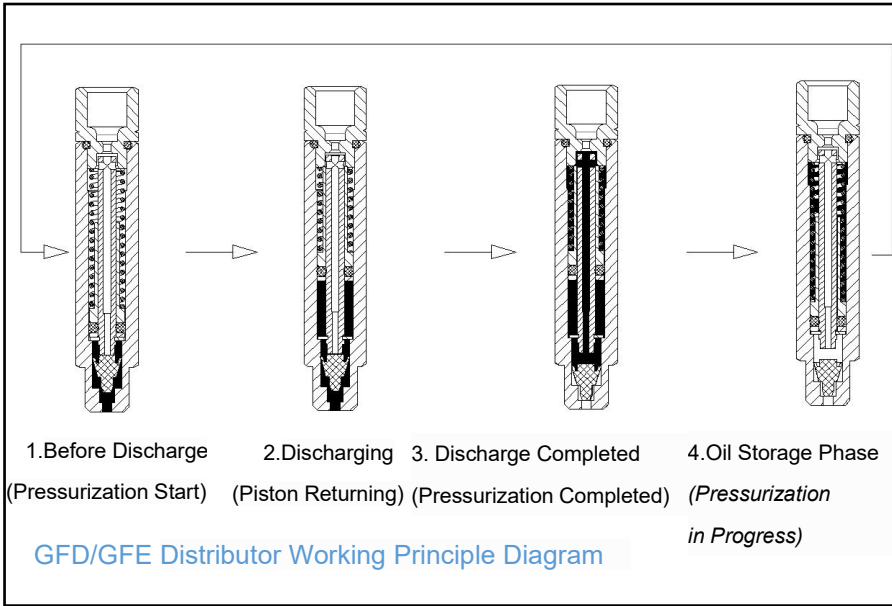

Working Principle of GFD/GFE Distributor

- 1. Lubricant Injection**
Pressurized grease from the pump forces the umbrella seal upward within the distributor.
- 2. Discharge Initiation**
When the umbrella seal closes the core rod center port, the piston overcomes spring resistance and rises, ejecting pre-stored grease from the chamber.
- 3. Discharge Completion**
At the piston's top dead center (TDC), grease discharge concludes with $\pm 2\%$ volumetric accuracy (ISO 4406 Class 8).
- 4. System Reset**
Upon pump shutdown: a) Pressure relief valve opens, returning oil to the reservoir. b) System pressure decays to $< 0.3\text{MPa}$. c) Spring-driven piston resets, transferring grease from the lower chamber to the upper chamber via the core rod orifice. d) The umbrella seal reseals the inlet, preparing for the next cycle.

VIII、 Quantitative Pressure-Release Grease Distrib

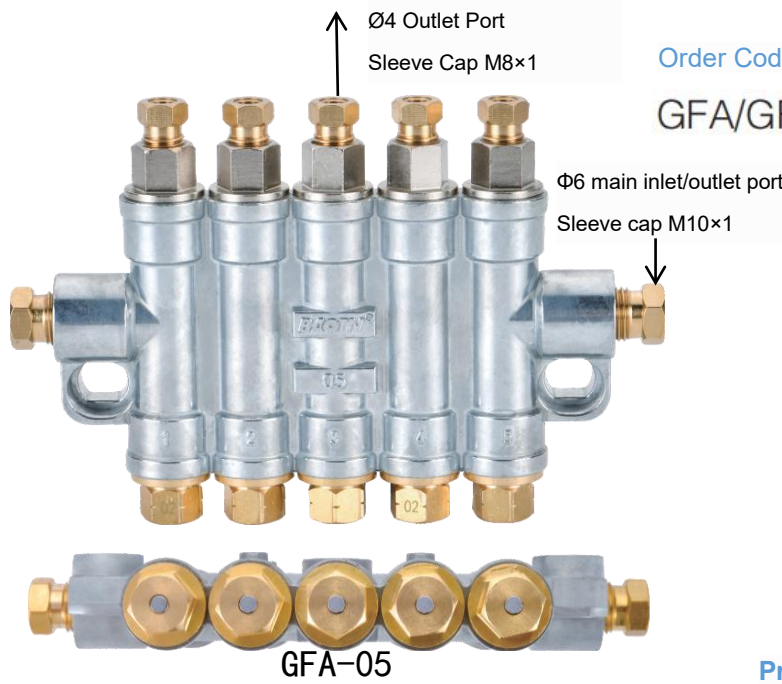

Order Coding Instructions

GFA/GFB - [] - [] - []

Number of Inlet Ports

b	Dual inlet ports
s	Single inlet port

Flow rate code

1	0.1mL
2	0.2mL
3	0.3mL
4	0.4mL
5	0.5mL

Number of outlet ports

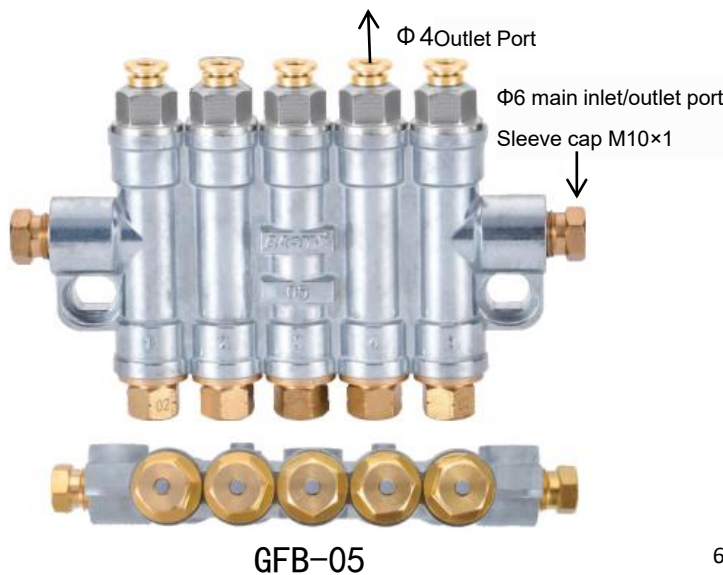

Product outline dimension drawing

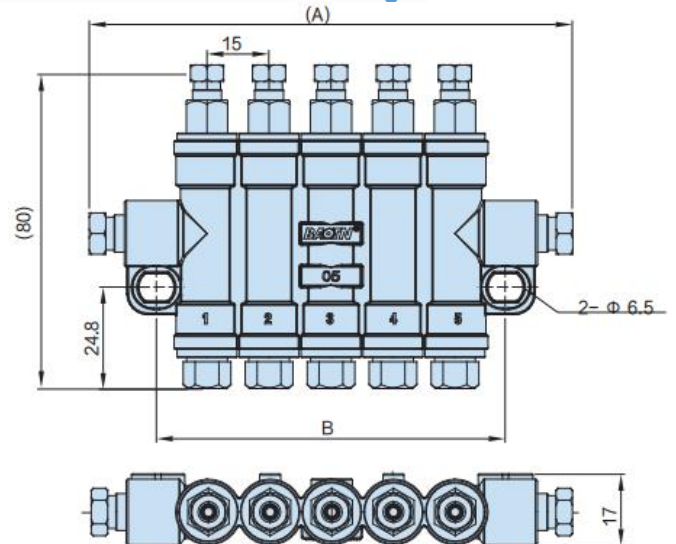

GFA/GFB-05

Model and technical specifications

Model number	Number of outlet ports	A	B	Discharge volume
GFA/GFB-01	1	69	39	0.1; 0.2; 0.3; 0.4; 0.5
GFA/GFB-02	2	69	39	
GFA/GFB-03	3	86	54	
GFA/GFB-04	4	102	69	
GFA/GFB-05	5	116.5	84	
GFA/GFB-06	6	160	105	
GFA/GFB-07	7	144	107	

Flow rate designation method:

1. Uniform flow rate: When all outlet ports have identical flow rates, specify with a single value.

Example: GFA/GFB-05-2 indicates all 5 outlets deliver 0.2mL/cycle.

2. Mixed flow rates: For varied outputs, list values sequentially.

Example: GFA/GFB-05-53235 denotes outlet flows as 0.5/0.3/0.2/0.3/0.5 mL/cycle (ports 1–5 respectively).

GFA/GFB Distributor working principle diagram

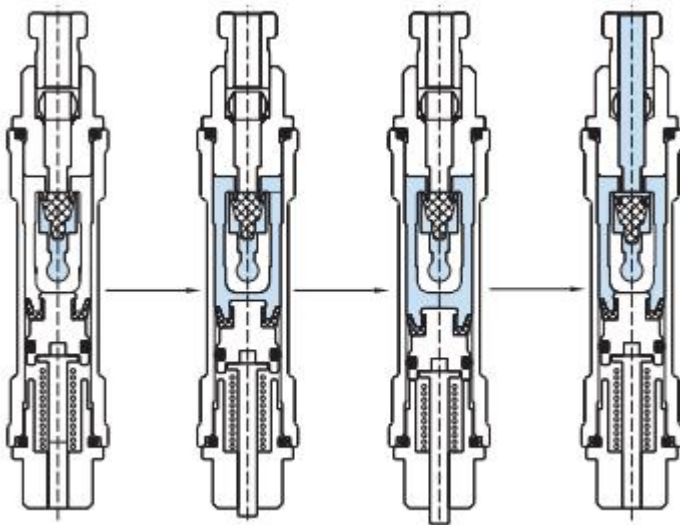

1. Before oil storage (Pressurization start) 2. During oil storage (Pressurizing) 3. Oil storage completed (Pressurization complete) 4. During discharge (Piston returning)

GFA/GFB Distributor Working Principle Description :

1. Grease Injection

Lubricant from the pump pushes upward through the umbrella valve.

2. Sealing & Storage

The umbrella valve seals the outlet port. Oil pressure forces the storage block to compress the spring and descend, filling the chamber.

3. Storage Completion

The storage block reaches the chamber's top dead center (TDC), completing oil storage.

4. Discharge Phase

Pump stops → Pressure relief valve opens → System pressure drops.

IX、 Progressive distributor

This distributor delivers grease sequentially through interconnected pistons. A visual indicator shows operation status, while a sensor port enables blockage detection (alarm triggers at ≥8MPa). Multiple outlets can be merged for increased flow.

Specifications: Max pressure 35MPa, displacement 0.2mL/cycle (±5%), operating temperature -40°C to +70°C, compatible with NLGI 000-2 grease.



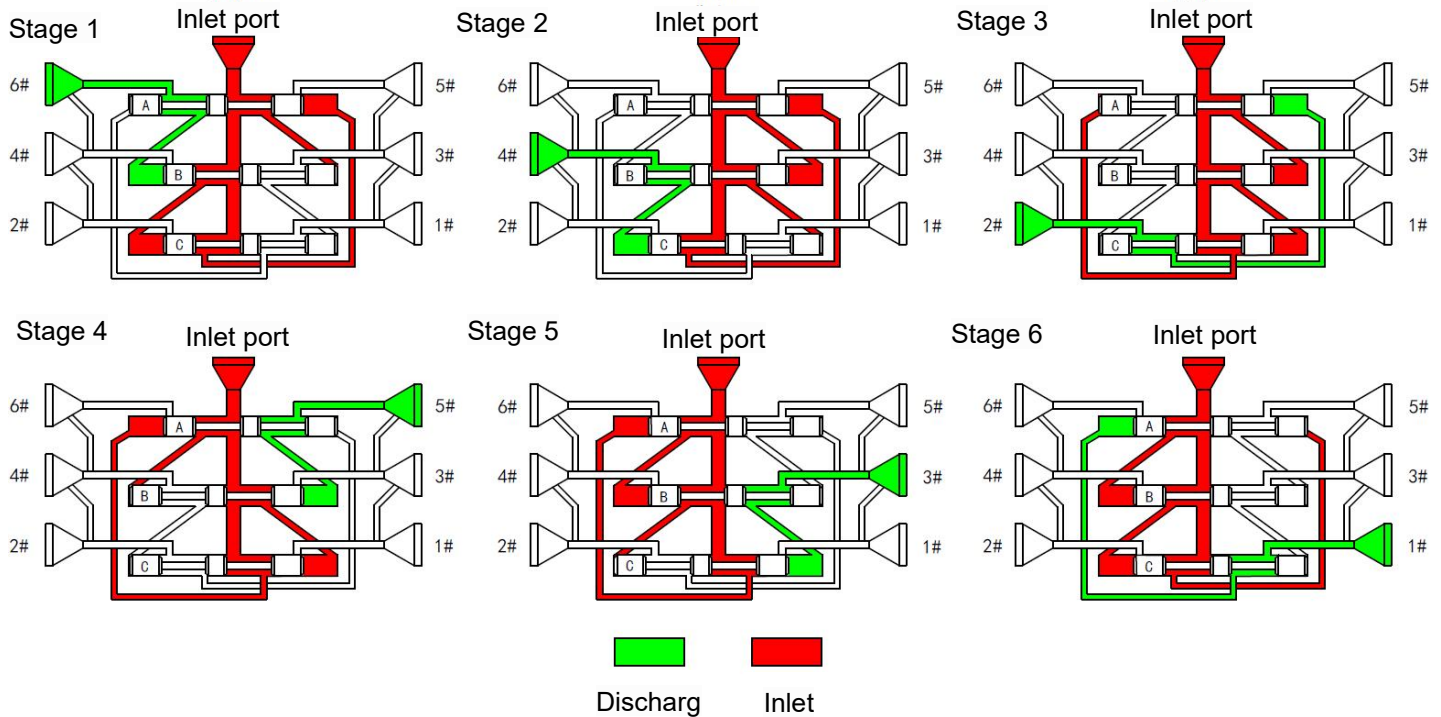

X、Operating Instructions and Precautions

1.GTC Performance Features

- ①The volumetric lubrication pump is equipped with a pressure relief device and must be used with volumetric distributors such as GFA/GFB/GFD/GFE/GFG/GFH;
- ②The resistive lubrication pump is not equipped with a pressure relief device and must be used with resistive distributors such as GPA/GPB/GPD/GFE;
- ③In the event of a system fault alarm, press the reset button (RST) after troubleshooting to restore the system to its set values and resume operation.

2. Type C PLC-Controlled Oil Lubrication Pump

(1) Performance Characteristics

- ①Equipped with a liquid level switch and a pressure switch (optional).An abnormal signal is output when oil volume or pressure is insufficient;
- ②The panel indicator lights display the power and lubrication status of the lubrication pump;
- ③The system includes a "FEED" key for forced lubrication;
- ④The motor features self-protection functions to prevent overheating and overload;
- ⑤An internal fuse is provided to prevent short circuits from causing excessive current that could damage the IC board and motor.

(2)Usage Instructions

- ①Install the lubrication system together with the corresponding distributor and pipeline;
- ②Ensure the input power matches the pump's operating voltage. Connect and secure the power wires according to the circuit diagram;
- ③Confirm that the pump body is grounded or connected to neutral to prevent electric shock or fire accidents;

- ④The factory-set working pressure for positive displacement pumps is 3MPa and 2MPa for resistance-type pumps. Do not adjust the pressure without authorization;
- ⑤Recommended lubricant: Clean NLGI Grade 000 Extreme Pressure Lithium Grease. The use of lubricants containing impurities is strictly prohibited;
- ⑥The oil supply time of the electric lubrication pump is controlled by an external PLC;
- ⑦Before connecting the main oil pipe, run the pump unloaded to expel air from the pump body. After air is expelled, connect the main oil pipe. Open the plug at the end of the system and add oil to expel air from the main oil pipe. Inspect the pipelines to ensure there are no leaks. Add oil until each lubrication point discharges oil.

(2)Precautions

- ※ For Type C electric lubrication pumps equipped with optional pressure switches, the external PLC programming should incorporate an insufficient pressure alarm function. Specifically, if the lubrication pump operates for an extended period while the pressure remains below the activation pressure of the pressure switch, the system should be considered abnormal. An alarm signal must then be triggered, and the lubrication pump should be immediately stopped for inspection and repair.
- ※ During the initial oil filling to the distributor on the main oil pipe, the process may take a longer time. Press the "RST" key repeatedly to continue oil filling until the pressure gauge reaches the rated pressure value . Simultaneously, inspect and ensure there is no oil leakage from the main oil pipe. Continue filling until oil is discharged from all lubrication points. If the buzzer alarms during operation, it may be due to detected insufficient pressure and is not a malfunction. Press the "RST" key to clear the abnormal alarm signal.

3.Usage and Instructions for Key Components

(1) Pressure Switch

The activation pressure of the pressure switch is the same as the operating pressure of the distributor. The pressure switch serves two main functions:

- ①For Type C electric lubrication pumps, the connection status of the pressure switch can determine whether the working pressure of the lubrication system has reached the oil discharge pressure of the distributor. It outputs a signal to the external PLC accordingly;
- ② For Type A electric lubrication pumps, the pressure switch detects insufficient pressure and triggers an alarm. Specifically, it provides a signal to the microcomputer controller by monitoring the system pressure. If the pressure does not reach the activation threshold, the system stops operation and triggers an alarm. However, the system allows an extension of approximately 15 seconds to enable the system pressure to reach the rated pressure. This ensures sufficient time for the quantitative oil cylinder in the distributor to accumulate oil, guaranteeing accurate oil delivery.

(2) Pressure Regulating Valve

If the system pressure is lower than the rated pressure, the lubrication time should be extended or the relief valve should be adjusted (must be performed by professionals). The specific adjustment steps are as follows:

- A.Disconnect the power supply to the lubrication pump and remove the oil tank;
- B.Loosen the lock nut counterclockwise, then tighten the adjustment screw clockwise to an appropriate position to compress the spring (it is recommended to adjust by half a turn at a time);
- C.Tighten the lock nut clockwise, then reinstall the oil tank and connect the main oil pipe;



D. Restore the power supply and check whether the lubrication pump reaches the rated pressure. If the rated pressure is not achieved, repeat the above steps.

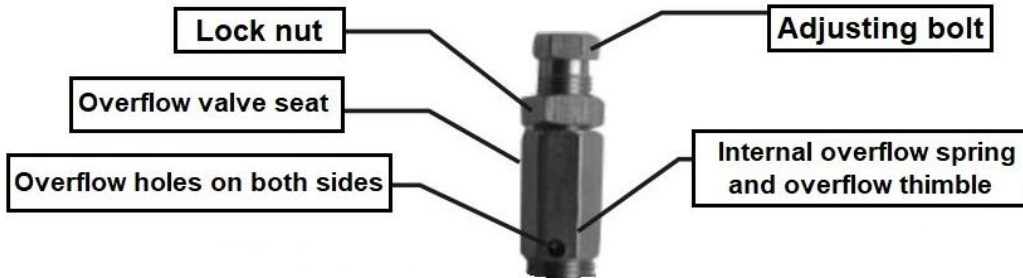



XI、 Troubleshooting and Solutions

S/N	Faults	Cause of faults	Troubleshooting
1	Motor does not start	Improper working voltage	Apply correct voltage
		Wrong wiring	Connect wires in the right way
		Gear pump jammed due to fine sand particles	The bottom gear pump must be removed for cleaning by a professional person
		Wires connecting the motor and control pane get loosened or motor heats up and stops automatically	When motor temperature drops to normal, the motor will recover on its own .It is suggested to adjust the lubrication time below 2 min and intermission time above 5 times of lubrication time
2	Insufficient pressure	Pressure gauge damaged	Replace the pressure gauge
		Main oil pipe leakage	Inspect the main oil pipe and eliminate any leakage
		Severe oil discharge from a branch pipe during pressurization	Check and replace the leaking branch pipe
		Sealing of lubricator overflow valve is not good	Remove for cleaning
		Oil suction port is blocked	Clean the oil tank and filter screen at the suction port
3	NO oil output	Air is not drained out of the pump	Repeat the oil priming process. If necessary, loosen the outlet port before priming
		Motor does not start	See S/N 1
4	Insufficient oil output	Oil suction port is blocked	Clean the filter screen at the suction port
		Sealing of lubricator overflow valve is not good	Remove for cleaning
5	Pressure Switch failure	Insufficient system pressure	Check the pipeline pressure. It must reach the rated pressure.
		Wrong wiring	Re-wire according to the correct wiring diagram.



宝腾智能润滑技术(东莞)有限公司

BAOTN INTELLIGENT LUBRICATION TECHNOLOGY (DONGGUAN) CO.,LTD.

宝腾智能润滑技术(东莞)有限公司

BAOTN INTELLIGENT LUBRICATION TECHNOLOGY (DONGGUAN) CO.LTD.

总部地址:广东省东莞市松山湖园区南山路 40-3 号

ADD: Building No 40-3, Nanshan Road, Songshan Lake Park,

Dongguan City, Guangdong Province

华东工厂:南京市溧水区经济开发区南区水保路 1 号

East China Factory: No. 1, Shuibao Road, South District, Economic Development Zone, Lishui District, Nanjing

华南工厂:东莞市大岭山汇鑫工业园 2 栋

South China Factory: Building 2, Huixin Industrial Park, Dalingshan, Dongguan City

总机(Switchboard):0769-88697068

传真(Fax):0769-88697067

Sales Manager: Candy Luo

Phone number:+86 18822972886

E-mail: 6687@baotn.com

www.baotn.com.cn

全国服务热线:400-880-8722

注:本畫册内說明文字、圖樣及技術參數隨技術發展而更改,恕不另行通知。

Note: The words, designs and technical parameters are subject to change along with the development of technologies without prior notice.



企业官网



微信公众号

代理商 (Agent):