

Company ADD: Building 4, No.3 Nanshan Road, Songshanhu Park,
Dongguan City, Guangdong Province
Switchboard: 0769-88697068
Fax: 0769-88697067
Sales hotline: 0769-81769706 81609360
Sales fax: 0769-85645035
E-mail: info@baotn.com

Kunshan Office:
ADD: D8-10, Mould Manufacturing Zone, International
Mould City, Yushan Town, Kunshan City, Jiangsu
Province, China.
Tel: 0512-36825633 13549490118 (Mr. Li)

Tianjin Office:
ADD: Room C2-111, North Hardware City,
Dongli District, Tianjin City, China.
Tel: 022-86882188 18622929211
Fax: 022-86882188-608
E-mail: tjbaoteng@163.com

Shenyang Office:
ADD: No. A1-14, Phase II, Zhonggang Hardware City,
Yuhong District, Shenyang, Liaoning Province, China.
Tel: 024-25198303 15332151880 (Mr. Yi)
Fax: 024-25198303
E-mail: tjbaoteng@163.com

Xi'an Office:
ADD: Room 505, Unit 2, Building 5, Shidaihuacheng,
Shuangyong Road, Weiyang District, Xi'an City,
Shanxi Province, China.
Tel: 19894599000 (Mr. Wang)

Jinan Office:
ADD: Room 202, Unit 1, Building 5, Tianyuanxinyuan,
Jianwei Road, Licheng District, Jinan City,
Shandong Province, China.
Tel: 15315550551 (Mr. Weng)
E-mail: 15315550551@qq.com



GEP Progressive grease lubrication pump

CENTRALIZED LUBRICATION DEVICE



Focus on reducing friction and increasing efficiency, and achieve the core competitiveness of customers.

[http://www.baotn.com.cn/\(Chinese Wbsite\)](http://www.baotn.com.cn/(Chinese Wbsite))
[http://www.baotn.com.cn/\(English Wbsite\)](http://www.baotn.com.cn/(English Wbsite))

Note: The words, designs and technical parameters are subject to change along with the development of technologies without prior notice.



Official website



WeChat official account

(Agent):



Contents

1.Safety instructions-----	①
2.Statement -----	①
3.Overview -----	②
4.Dimension and working principle -----	②
5.Model description -----	③
6.Product specification and technical parameters -----	③
7.Description on principle Of distributor (measuring piece) -----	④
8.Oil supply cycle and installation-----	⑥
9.Refueling tools and their instructions-----	⑦
10.Maintenance -----	⑦
11.Trouble shooting -----	⑧
12.Transportation and Storage-----	⑧



copper gaskets, or other sealing methods, they must be replaced with new combination gaskets or copper gaskets during

5. Remove dirt from all parts of the entire system and oil leakage from lubrication points;
6. Check the remaining oil in the fuel tank and replenish it in a timely manner;
7. Keep maintenance records;

11. Troubleshooting

Fault phenomenon	Fault source	Excluding Offences
Lubricating pump does not output oil	Motor does not rotate	Testing the motor and wiring
	Pump air instead of oil	Exhaust air
Insufficient lubrication pump pressure	Low plunger pressure	Replacing the plunger
	Safety valve failure	Replace the safety valve
Insufficient pressure (Single line type)	Oil pressure sensor damaged	Replace the oil pressure sensor
	Oil pressure plug-in loose	Reinsert tightly
	Pipeline leakage	Identify leakage points and resolve faults
	System blockage (progressive)	Check the faulty distributor and replace it
Insufficient oil quantity	Lubricating pump is out of oil	Adding grease

12. Transportation and Storage

1. Transportation

- (1) When loading and unloading, it should be handled with care and not inverted;
- (2) During loading, unloading and transportation, collision with other items should be avoided;

2. Storage

- (1) The product should be stored in a well ventilated, dry warehouse that is not exposed to direct sunlight and does not contain corrosive gases in the air;
- (2) Close all open pipelines to prevent the intrusion of dust and impurities;
- (3) Products should be neatly stacked in the warehouse, pay attention to ventilation, and pay attention to the markings on the packaging box. They should not be inverted. The packaging box should be kept at least 100mm away from the ground and walls.



1. Safety instructions

The following signs are a reminder for safe use of the product	
	Please read the product user manual carefully before operation. Improper operation may cause damage to the product and personal injury
	Before product maintenance and repair, please cut off the power supply.
	Ensure that the shell of the product is properly grounded when wiring, otherwise it may cause serious damage to the product.
	Warning sign.

2. Statement

All components are produced in accordance with the rules of labor safety and accident prevention. There is still a possibility of danger during use, causing damage to users or third parties and property. Therefore, the use of the product should strictly follow the operating manual, and problems that can usually cause safety faults should be immediately eliminated.

●Exemption from Liability

BAOTN shall not be liable for damages caused by:

- Lack of lubricant
- Use solid lubricants or unsuitable lubricants
- Not used according to normal usage
- Installation or connection error
- Misoperation for troubleshooting

●Authorized Installation Technician

Only qualified engineers can install, operate, maintain, and repair this product. Qualified engineers refer to those who have been trained and appointed by the equipment user

Appointed personnel have received training, have experience, and are familiar with relevant standards, rules, accident prevention, troubleshooting, and operational conditions

●Transportation and storage

There are no restrictions on road transportation, air transportation, and sea transportation

●Environmental protection

Oil and grease are substances that are hazardous to land and water sources, so special safety regulations must be in place for storage, handling, and transportation.



3. Overview

GEP electric grease lubrication pump is designed and manufactured specifically for supporting various large and medium-sized machinery, which is very economical and practical. It is suitable for engineering machinery, CNC machinery, processing centers, production lines, textile, plastic, printing, chemical, food and other mechanical industries, ensuring the lubrication performance of various mechanical products, extending the service life and accuracy of mechanical equipment.

The GEP progressive electric grease lubrication pump can also form a resistance lubrication system with a GSA/GPA/GPB/GPC model proportional joint or progressive distributor to provide oil injection lubrication for lubrication points; This type of electric grease lubrication pump has various voltages for selection: AC110V, AC220V, DC24V. Different models of lubrication pumps can be selected based on the different hosts used by users. Optional configuration includes a pressure switch, a low oil level transmitter, and a matching host computer system to achieve integration of shutdown, lubrication, and alarm.

4. Dimension and working principle

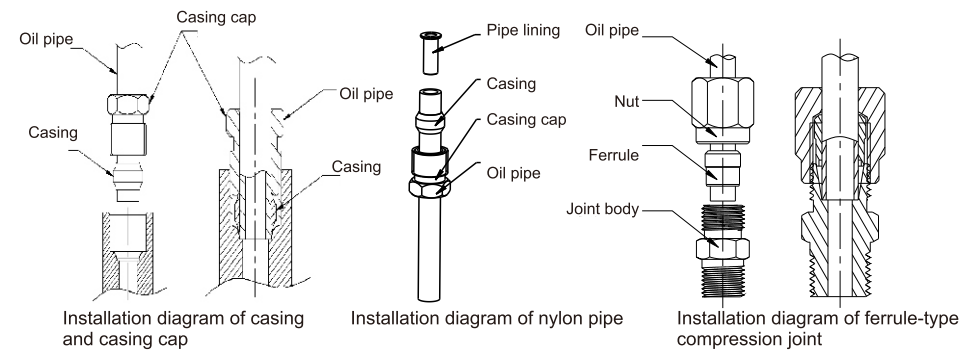
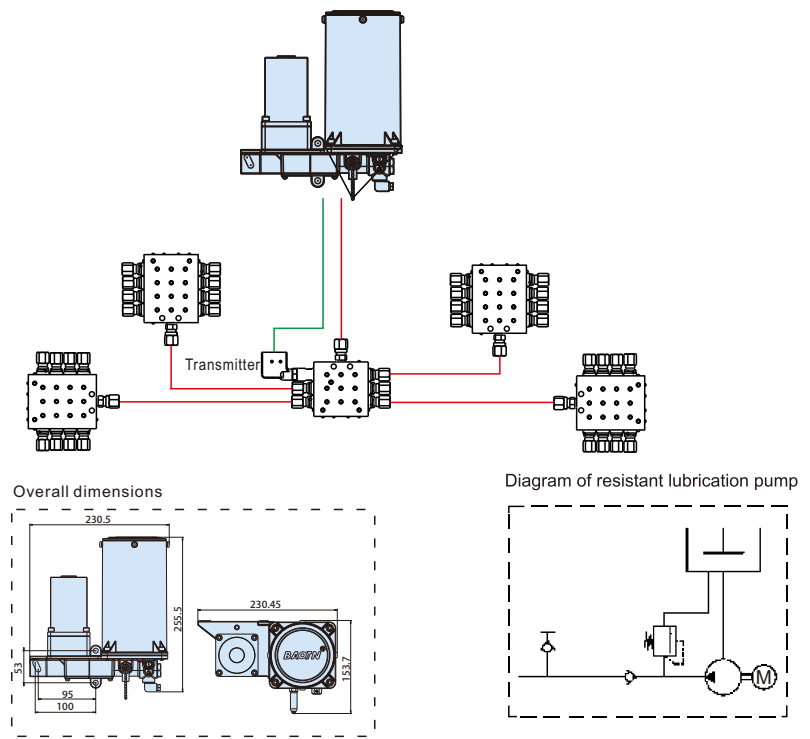

1. The oil gun uses a push-in fitting to quickly fill the lubrication pump with oil.
2. Technical parameters: working pressure: 1.5MPa; maximum displacement: 20ml / time; used medium: thin oil (mechanical oil) $\geq 32\#$; grease (lithium-based grease) 000 # - 0 #.
3. How to use the push-in fitting:
 - 3.1 Insert the oil gun into the oil tank, operate it to discharge the oil from the oil outlet (push-in fitting nut); then insert the lubrication pump's push-in fitting and operate the oil gun to supply oil to the lubrication pump.
 - 3.2 GEN type pump is a closed vacuum lubrication pump. When the injected oil gradually lifts the oil cover in the oil tank to the highest position (exhaust hole), please operate the oil gun slowly to supply oil to the lubricating pump to make the oil with air bubbles discharged from the vent hole. The supplied oil must be pressed against the lower end of the oil cover to generate a vacuum state, thus realizing the vacuum suction of oil without air bubbles.
 - 3.3 Exit: push forward the nut of the push-in fitting to the end to exit.
5. Please strictly follow the instructions for use, and the warranty will be invalid for operation in violation to the instructions.

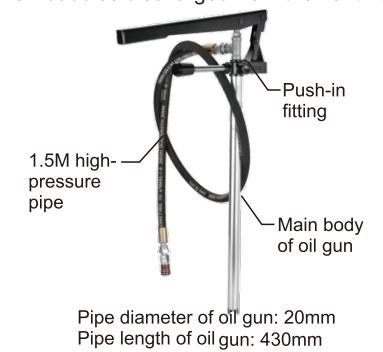

10. Maintenance

1. Manually start the lubricating pump and observe whether it operates normally;
2. Check whether the main oil pipeline and distribution pipeline have leaks or ruptures, and whether all lubrication points can be filled with grease;
3. Check whether the tube bundle is fixed and whether the wiring harness is securely connected;
4. During maintenance of the lubrication system, if the disassembled parts are sealed with combination gaskets, reinstallation



8.Oil supply cycle and installation instructions for lubrication system

1. Setting the oil supply cycle of the lubrication system

In a progressive system, the oil supply cycle of the lubrication system (the running time of the lubrication pump and the interval time of the lubrication pump) is set based on the number of lubrication points and the oil demand of the lubrication points. The following methods are recommended to determine the oil supply cycle of the lubrication system:

(1)The running time of the lubricating pump: the progressive distributor should be equipped with a cycle signal switch, and the running time is determined by receiving the number of pulses that the cycle switch is turned on and off.

(2)Determination of the minimum interval time of the lubrication system: determined by the oil quantity during the lubrication point interval and the oil supply quantity of the lubrication system each time.

Note: The lubrication pump motor is only suitable for intermittent operation and should not work for long periods of time.

2. Installation instructions for lubrication pump station

- (1) Live installation is strictly prohibited;
- (2) Ensure that the liquid level line on the oil tank is clear and clean during installation;
- (3) The installation surface should be flat and the installation connection should be reliable;
- (4) At least 1 meter away from the heat source.

3. Distributor installation instructions

- (1) The distributor should be installed firmly for easy maintenance;
- (2) During installation, the inlet and outlet of the distributor should be kept clean and tidy;
- (3) The distributor should be arranged as close as possible to the lubrication point (the longest oil distribution pipe for the progressive distributor should be less than 25 meters)

4. Installation instructions for lubrication system pipelines

- (1) The oil pipe should be cut vertically in the axial direction, and the pipe opening should not be cracked or scratched, nor should the oil pipe be flattened;
- (2) During installation, the pipeline must be kept clean and free of pollutants;
- (3) Pipeline piping must be short and concise to reduce system pressure loss and ensure smooth pipeline flow;
- (4) Minimum bending radius: 7.9*14.3 resin tube is R100, 4.0*8.6 resin tube is R60;
- (5) The connection of pipeline joints must be reliable and free from leakage.

5. Lubrication pump refueling instructions

- (1) The position of the liquid level upper limit label is set based on the exhausted for the first time volume;
- (2) When the oil pressure disc lubrication pump is refueled and exhausted for the first time, a small amount of grease will overflow from the exhaust hole in order to completely exhaust the air in the oil tank. This is within the normal allowable range, just wipe it off;
- (3) If there is air in the fuel tank during subsequent refueling, the same method as for the first refueling and exhaust is used. The oil is added to the exhaust hole position, and the piston automatically closes the exhaust hole after the air is discharged.



5.Model description

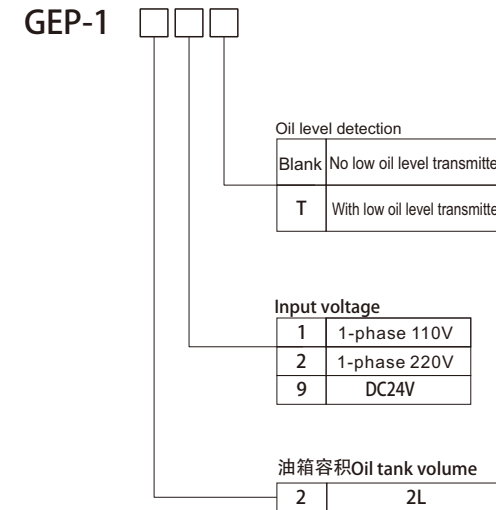

6.Product specification and technical parameters

model	flow	voltage	power	Fuel tank capacity	Oil outlet pipe diameter	Maximum discharge pressure	Oil viscosity
GEP-1	20cc/min	Unidirectional 110V	35W	2L	Φ6	8.0MPa	NLGI 000#-1#
		Unidirectional 220V	35W				
		DC24V	25W				

Performance and characteristics:

- The working cycle of the lubrication pump can be controlled through the host PLC or an independent controller.
- Equipped with a pressure regulating valve device, it can independently set the working pressure of the lubrication pump to ensure its safety.
- The lubrication system is equipped with a pressure switch, which can effectively monitor insufficient pressure such as flow interruption and leakage in the lubrication system pipeline.
- Equipped with an exhaust valve device, it can remove air from the lubrication pump chamber and ensure smooth oil discharge from the lubrication pump.
- Equipped with a low oil level transmitter, the normally open or normally closed contacts can be selected according to the system.
- Adopting a spring type oil pressure plate and vacuum oil suction.
- Please use a grease gun to add grease to the lubrication pump storage tank through a grease filter, which can prevent impurities and air from entering the lubrication system and improve the effectiveness of the lubrication system.
- In resistive systems, there is no pressure relief valve device, it can form a resistance system with a GSA proportional joint, or use with a progressive distributor GPA/GPB/GPC to achieve quantitative oil supply.



7. Description on principle of distributor (measuring piece)

1. GSA type proportional grease joint and GPA type progressive grease distributor

Outline dimensional drawing

Grease measuring piece

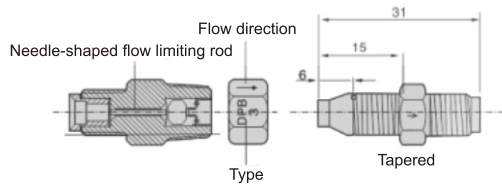
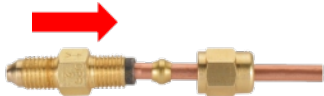

Specifications and technical parameters

GSA	Types	Mark	Flow rate (cc/mm)	Connection mode Connect with the (JQC-BB04 type) oil distributing block at the oil inlet. Connect with (the JQC-BB04 casing) and (the JQC-BP04 casing cap) at the oil outlet. Commonly used pipe branches and terminals)
	GSA-1	GSA1	30	
	GSA-2	GSA2	35	
	GSA-3	GSA3	42	

Remark: flow test values for the proportional joint (please refer to the #000 oil).

Performance and features

- The GSA type joint is also called proportional joint.
- It is of a tubular structure with a flow limiting rod inside.
- Cracking pressure: 8kgf/cm²
- The flow is controlled according to the throttling principle and proportionally distributed according to the flow capacity (flow rate).
- The same types of measuring pieces have a certain difference in oil output in actual use according to the distance among them in the lubrication system or the installation mode, that is, horizontal or vertical.
- Flow ratio: the flow rate of the same models will change due to changes in ambient temperature and viscosity of the oil during actual use.

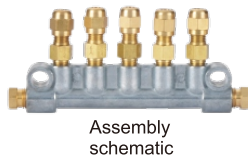

GPA type progressive grease distributor

Type specification

GPA -		M	Circulating indicator equipped
		R	No circulating indicator

Number of oil outlets	Type specification
02	2 oil outlets
03	3 oil outlets
04	4 oil outlets
05	5 oil outlets
06	6 oil outlets
07	7 oil outlets
08	8 oil outlets
09	9 oil outlets
10	10 oil outlets
11	11 oil outlets
12	12 oil outlets



Scope of application

- The progressive grease distributor is an advanced, well-structured oil distributor. It can be combined with manual, electric or pneumatic lubrication pump to form a single-line lubrication system, being an ideal product suitable for a variety of small and medium-sized machine tools and plastic machines and equipments as well as similar application. A set of GPA type distributors can usually provide lubrication for 4, 6, 8, 10 or 12 lubrication points. The flow rate of the GPA type distributor is always 0.3cc/cy

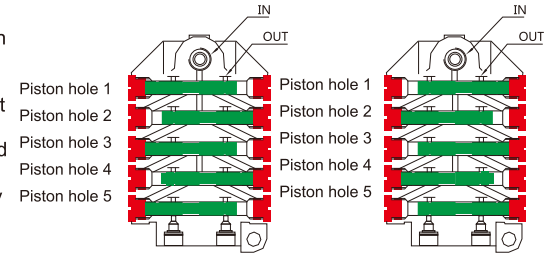

***Remark: the oil outlets of the oil distributor cannot be blocked, otherwise the normal operation will be affected and the distributor will be damaged.**

Action graph

Technical parameters of GPA type distributor

- Max. nominal pressure: 60kgf/cm²
 - Standard capacity: 0.3cc/cy
 - Range of applicable lubricants (at standard temperature): lubricating oil \geq R68, grease 000° -0°.
 - Working environment temperature: -10 °C ~ +60 °C
 - Max. circulation speed of piston pair with mechanical circulation indicator: 60cy/min
 - Max. circulation speed of piston pair: 200cy/min
 - Number of lubricating points that can be lubricated by a set of distributors: 2, 3, 4, 5, 6, 7, 8, 9, 10, 11, 12
- Optimal diameter and length of distributor output pipe: Φ 4mm; 0.5m to 2.5m long.
Housing material: aluminum alloy

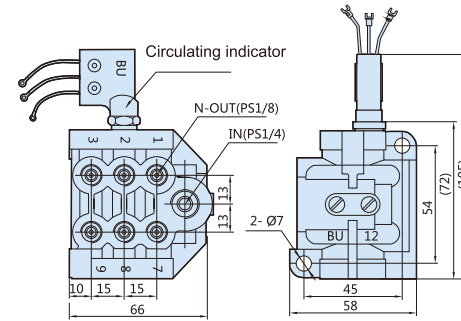

GPA-10R/GPA-12R type grease distributor

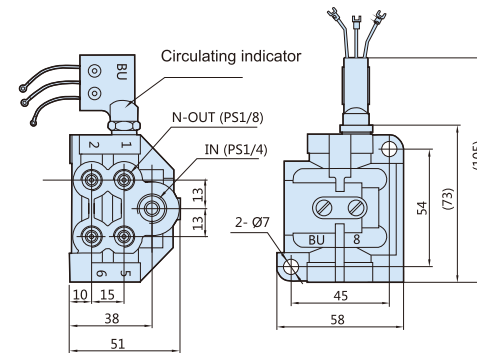

GPA-4R/GPA-6R/GPA-8R type grease distributor

Type	Detection distance	Number of outlets	Theoretical output (cc/cy)	Weight (g)
GPA-2R	0	2	0.3	300
GPA-3R	0	3		300
GPA-4R	0	4		300
GPA-5R	0	5		300
GPA-6R	0	6		300
GPA-7R	0	7		300
GPA-8R	0	8		300
GPA-9R	0	9		400
GPA-10R	0	10		400
GPA-11R	0	11		400
GPA-12R	0	12		400