

使用说明书

BTB型稀油电动润滑泵

CENTRALIZED LUBRICATION DEVICE



专注减摩增效，成就客户核心竞争力



Table of Content

I.Application and Features-----	①
II.Product specifications and Technical Parameters-----	②
III.Overall and Installation Dimensions-----	②
IV.Electrical Wiring Diagram-----	③
V.Instructions for Use of Panel-----	③
VI.Usage and Debugging of Lubricator-----	④
1.BTB-C2 -----	④
2.BTB-C1-----	④
3.BTB-A2-----	⑤
4.BTB-A1-----	⑦
VII.Maintenance-----	⑦
VIII.Common faults and troubleshooting methods-----	⑧



Thank you for using BAOTN BTB type thin-oil electric lubricator! Our BAOTN centralized lubrication systems include manual and electric thin-oil lubricators, manual and electric grease lubricators, or NC gear lubricators as well as matching distributors. Before use, please read this manual carefully so that you can master the correct usage of lubricator and make the most of outstanding performance. Thanks for your cooperation!

I. Application and Features

BTB type thin-oil electric lubricator is specially designed for the medium and small-size machinery, economic and practical. This product can ensure the lubricating performance and improve their service life and precision, applicable to CNC machines, processing centers, production lines, light, textiles, plastics, Printing, chemical industry, woodworking, food industry etc.

The BTB type dilute oil electric lubricator can be combined with a quantitative positive displacement distributor to create a positive displacement lubrication system for precise oil injection at lubrication points. When used with our company's BFA, BFD and other models of quantitative positive displacement distributors, it maximizes lubrication efficiency. Additionally, it can integrate with BSA, BSC, CZA, and BSB proportional connectors to form a damping lubrication system, enabling proportional oil injection at lubrication points according to predetermined ratios.

The BTB type dilute oil electric oil pump offers three-liter and four-liter high-strength plastic tanks, or 6-liter and 8-liter metal tanks for selection. Different models can be chosen based on specific applications and the host equipment of the user. The selected model is equipped with level switches and pressure switches, which can connect to the host computer system to achieve integrated functions of intermittent operation, lubrication, and alarm monitoring. When choosing a microcomputer-controlled oil pump, users can freely set the intermittent operation and lubrication intervals for the lubrication system. The pump features an elegant design with a buzzer for abnormal alarms and provides NO/NC interfaces for easy operation.

The product has the following features:

1. Easy installation and simple wiring.
2. The special alloy steel gear pump has stable output pressure, low noise and long service life.
3. It has the detection and warning function of insufficient liquid level and abnormal pressure.
4. Automatic pressure relief structure, reliable and excellent performance of pressure relief action. If used with the quantitative volume dispenser produced by our company, the lubrication effect can be fully brought into play.
5. The low-speed motor is used to reduce the wear of the gear pump, and the motor is equipped with a heat dissipation device to achieve long-term operation.
6. The IC control part of the microcomputer oil filling machine uses high quality microcomputer, which has the characteristics of high reliability and stability. The intermittent action time can be freely set, and the operation is simple and easy to understand. It has strong anti-interference ability and can be used in harsh environment.

II. Product specifications and Technical Parameters

Type	AC voltage	power W	Control function	Rated Pressure MPa	Max pressure MPa	Displacement cc/min	Oil tank Capacity L	Oil viscosity cSt
BTB-A2	Single-phase-110/220v	25 40 60	MPU control	1.5~1.7	3.5	100	3 (resin) 4 (resin) 6 (steel) 8 (steel)	30~250
BTB-C2	Three-phase-220/380v		PLC control			200 300		
BTB-A1	Single-phase-110/220v	25 40	MPU control	1.0		200		
BTB-C1	Three-phase-220/380v	60	PLC control			300		



Continuous-type electric lubricator NO. (serial number note to the corresponding position)

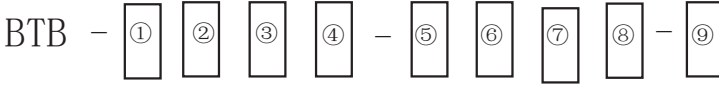

- ① Control type:
A: digital display microcomputer controller
C: external PLC control
- ② System type:
1: resistance mode (without a pressure-release Device; used with resistance-type distributors)
2: positive displacement type (with a pressure-release device; with volumetric distributors)
- ③ P: With pressure switch
Blank: No pressure switch
- ④ Oil tank capacity :
3: 3L 4: 4L 6: 6L 8: 8L
- ⑤ Type of motor:
1 : single-phase 110V
2 : single-phase 220V
3 : Three-phase 380V
8 : DC 12V
9 : DC 24V
- ⑥ Displacement:
2 : 200cc/min
3 : 300cc/min
- ⑦ Output port aperture:
4 : Out pore is $\phi 4$
6 : Out pore is $\phi 6$
- ⑧ W: No level switch
Blank: With level switch
- ⑨ A : The metal tank does not have a return oil device
H : Metal tank with oil return device

III. Overall and Installation Dimensions

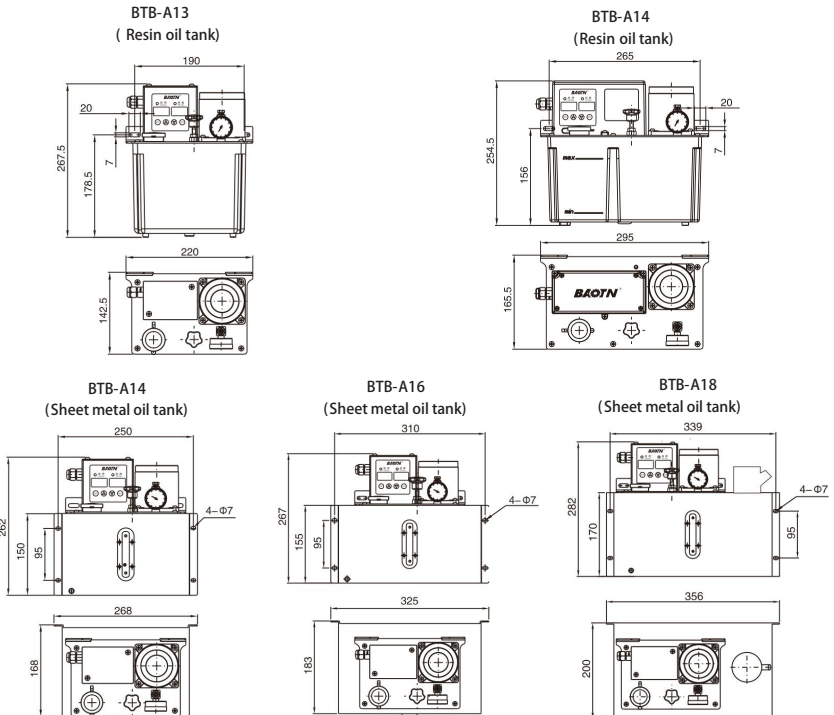



IV. Electrical wiring diagram: (Inside the junction box)

- A circuit diagram of the A type

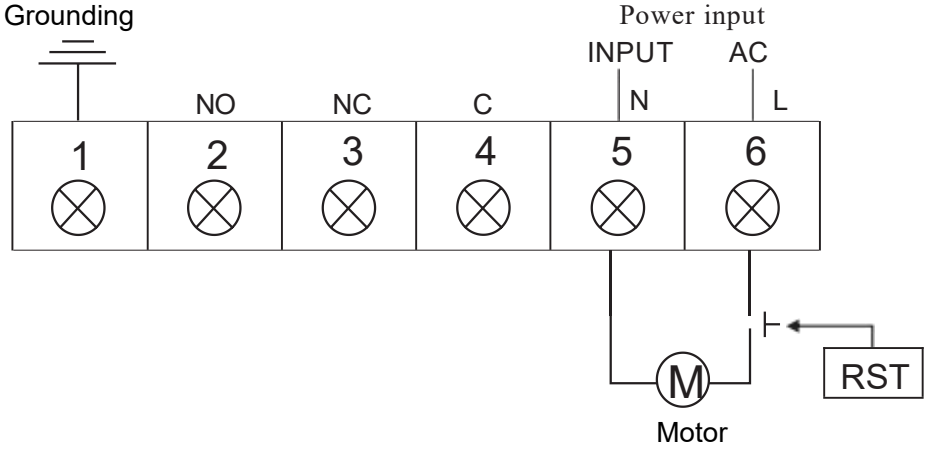

- C Type circuit wiring diagram

Note: Terminal C.L of 6.7 cannot be connected to external power cord at the same time.

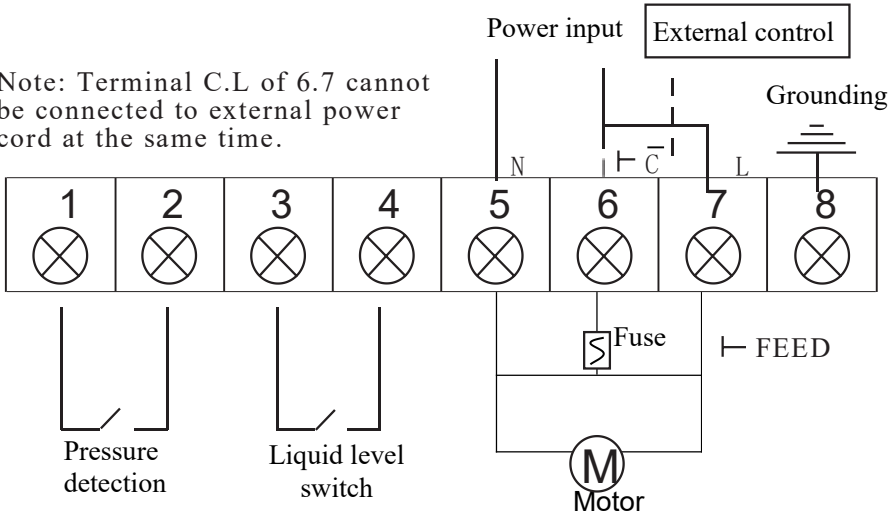



● Pressure Switch A Type

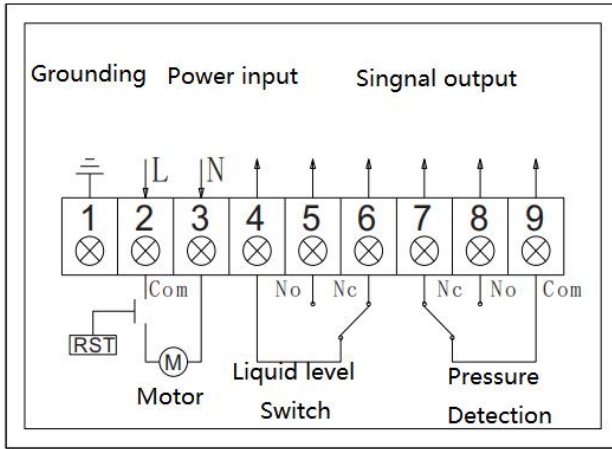

V. Instructions for Use of Panel

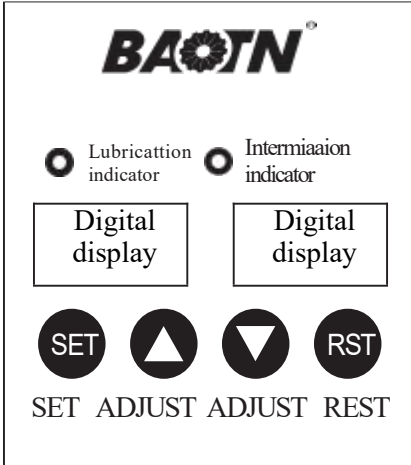

Description of A-type panel

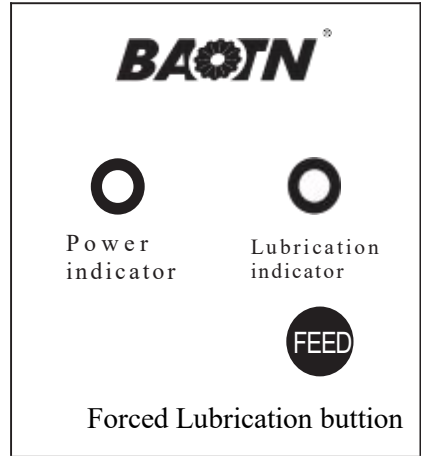

Description of B-type panel



VI. Usage and Debugging of Lubricator

1. BTB-C2 electric lubricator and a detection volumetric quantitative distributor compose the lubrication system

(1) Confirm that the electric oil filling machine with pressure relief mechanism is attached to the selected machine.

(2) Add an appropriate amount of unused clean lubricating oil to the tank.

(3) Connect the wiring correctly according to the electrical wiring diagram in the pump top cover.

(4) The use of pressure switch: the operating pressure of the pressure switch is set to 9 kgf/cm^2 , which is the same as the operating pressure of the volume distributor. There are two ways to use the pressure switch:

① The operation of the pressure switch determines whether the lubrication system's working pressure reaches above 9 kgf/cm^2 , indicating potential system abnormalities. For the BTB-C electric oiling machine, the lubrication duration is externally controlled by a PLC. The system automatically sets this duration based on the time required to reach the rated pressure of 15 kgf/cm^2 . The intermittent operation interval can be freely adjusted according to consumption duration or operational cycles.

② When pressure insufficient to reach 9 kgf/cm^2 , the pressure switch activates (at approximately 9 kgf/cm^2) to signal the main computer controller, stopping the motor at 10-second delay is intentionally included to allow the system pressure to stabilize at 15 kgf/cm^2 , ensuring sufficient time for the metering cylinder in the dispenser to accumulate oil accurately. The external PLC also controls the intermittent intervals based on specified durations cycles. Critical safety measures: If the lubrication system fails to reach 9 kgf/cm^2 , the pressure switch will malfunction malfunction, causing continuous motor operation. To protect the motor, the program includes a safeguard mechanism: if the motor runs continuously for 4 minutes without stopping, it triggers an abnormality alert, immediately halting the motor for maintenance.

(5) Confirm that the pump body is connected to the grounding wire or zero line, so as to prevent electric shock and fire accidents.

(6) Connect the power supply, start the oil injection, pre-inject the oil, drain all the air in the lubrication system, and check the main oil pipe to ensure that there is no leakage. Oil until each lubrication point is out of oil.

※ Note: During system inspection or operation, each oiling cycle requires pressurizing the system to 15 kgf/cm^2 . The indicator rod at the rear of each dispenser port should protrude under this pressure. If not, immediately check both system pressure and the dispenser's plunger components. When system pressure drops below 15 kgf/cm^2 , either extend the lubrication duration or adjust the relief valve. Specific adjustment procedures are as follows:

A. Disconnect the power supply of the oil filling machine, remove the oil tank and block the main outlet of oil filling.

B. Loosen the locking nut, turn the adjusting bolt clockwise to the appropriate position, and confirm that the pressure of the oiling machine reaches the rated pressure of 15 kg f/cm^2 .

C. Secure the locking nut, then install the oil tank and attach the main oil pipe. If the system pressure reaches the rated value of 15 kgf/cm^2 and the signal rod at the rear end of the distributor's specific section remains non-protruding, remove the copper joint and its associated plunger (piston). Replace any missing seals, faulty joints, or damaged plunger components.

(7) Start the oil pump and enter the normal working state.

2. BTB-C1 electric lubricator and a resistance-type proportional distributor (measuring part) compose the lubrication system.

(1) There is no need to attach a pressure relief mechanism when selecting an electric oil pump, but the oil pump with a pressure relief mechanism can also be used, but it needs to be equipped with a single connection.

(2) Fill the tank with an appropriate amount of unused clean lubricant.

(3) Connect the wiring correctly according to the electrical wiring diagram inside the pump top cover.

(4) Pressure Switch: In this lubrication system, where the pressure is typically low ($2\text{--}5\text{ kgf/cm}^2$), it is generally not installed. The BTB-C electric oiling machine's time setting is controlled by an external PLC, with the lubrication duration determined by actual operational requirements. The intermittent operation time can be freely configured based on either the required lubrication duration or the number of working cycles (closing operations).



(5)Confirm that the pump body is reliably grounded or connected to zero, in case of electric shock and fire accidents.

(6)Connect the power supply, start the oil injection, pre-inject the oil, drain all the air in the lubrication system, and check the main oil pipe to ensure that there is no leakage. Adjust the oil distribution ratio of the distributor (metering component), and inject oil until each lubrication point is oiling.

(7)Start the oil pump and enter the normal working state.

3. BTB-A2 soft-touch digital display MRU electric lubricator and a detection volumetric quantitative distributor compose the lubrication system.

(1)Confirm that the electric oil filling machine is equipped with pressure relief mechanism.

(2)Fill the tank with an appropriate amount of unused clean lubricant.

(3)Connect the wiring correctly according to the flash circuit diagram of pump top cover.

(4) Confirm that the pump body is reliably grounded or connected to zero, so as to prevent electric shock and fire accidents.

(5)A type of touch digital display microcomputer controller features and technical parameters:

Touch-type digital display microcomputer controller is a new generation of microcomputer time controller with dual setting and dual timer. It has the advantages of convenient setting, digital display, multiple fault alarm prompts, high timing accuracy and reliability.

A.the system can set three action modes:

1.Lubrication: Start with a lubrication time timer.

2.Intermittent: The interval time is counted after the lubrication is completed.

3.Memory: Powering on again after a power failure allows you to continue executing the previously unfinished interval.

B.The lubrication and interval time can be set by yourself, and the setting range is (the lock key function is set inside, which can lock the lubrication and interval time after setting):Lubrication time: 1~999S (second) INT interval time: 1~999M in (minute)

C. The system alarms under the following conditions and alarms for a period of time.

1.Insufficient pressure indicates Erp

2.level insufficient indicates Ero

3.The panel indicator light can show the lubrication and intermittent status of the system.

D.In any case, the controller can force lubrication or eliminate abnormal alarm signals by pressing the "RST" key.

E、 Control relay output is AC 250V,5A fault relay output is AC 250V,0.5A

F、 Controller operating voltage, AC 110/200±20% 50/60Hz.

(6)Usage of Type A touch digital display microcomputer controller:

A.To configure lubrication duration: Press the SET button for 2 seconds to activate the ON mode. The digital display will show the original ON lubrication time value. Adjust this value using the up/down keys until desired settings are achieved, then hold down the SET button for 2 seconds to enter OFF interval configuration. The display will now show the original OFF interval value in a scrolling format. Set the desired OFF interval using up/down keys, then press the SET button again for 2 seconds to confirm settings. The data is stored in memory and displayed in real-time, with the system automatically restarting operations according to the new parameters.

B.The controller is connected to AC 110V/220V power supply and can enter the working state. The ON and OFF states cycle according to the set time. C. When the system has a fault alarm, the system will return to the set value and start running after abnormal processing by pressing the reset button (RST).



(7)Set the operating lubrication time and intermittent time.

1. When the power is activated, the controller enters the LUB lubrication mode. At this stage, the oiling machine operates in lubrication mode, measured in seconds (s). By setting an appropriate oil supply duration (1.5-30 seconds) or performing multiple lubrication cycles, the machine will repeatedly dispense oil to pre-fill the system. This process thoroughly purges air from the lubrication system and inspects the main pipes for leaks. Oiling continues until each lubrication point is fully lubricated.

2. Setting the oil supply duration: The duration must exceed the time required for the oiling machine to fully discharge oil into the distributor reservoir, ensuring all tail signal rods of the distributors extend beyond the preset threshold. This is determined by the system pressure reaching its rated value of 1.5MPa. When this condition is met, the oiling machine stops operation, triggering the pressure relief mechanism. The internal spring in the distributor then pushes the piston to deliver precise quantities of lubricant to each lubrication point. Setting the intermittent rest period: The rest (intermission) interval should be selected based on the lubrication status of each point, typically ranging from 15 minutes to 4 hours.

It takes long to feed oil to the main pipe distributor for the first time. It is required to press RST repeatedly so that the pressure gauge indicates the rated pressure of pump. At the same time, through visual inspection, make sure that the main pipe has no leakage. Feed oil until each lubrication point shows oil. In operation, buzzing alarms results not from faults but from insufficient pressure.

(8) Start the host into working state, and the controller will work in a loop according to the set time

4. BTB-A1 soft-touch digital display MRU electric lubricator and a resistance-type proportional distributor (measuring part) compose the lubrication system

(1) There is no need to attach a pressure relief mechanism when selecting an electric oil pump, but the oil pump with a pressure relief mechanism can also be used.

(2) Fill the tank with an appropriate amount of unused clean lubricant.

(3) Connect the wiring correctly according to the electrical wiring diagram inside the pump top cover.

(4) Confirm that the pump body is connected to the grounding wire or zero line to prevent electric shock and fire accidents.

(5)(6)(7) Same as Item(5)(6)(7) in the previous section

(8) Pressure switch: In this lubrication system, because the pressure is low, generally 2~5 kgf/cm², pressure switch is generally not installed (9kgf/cm²).

Note: If the pressure opening oil pump is selected, the pressure switch must be shorted to keep it on to disable the alarm function. Otherwise, the lubrication pump will not work.

(9) The oil supply time is set according to the actual oil supply situation. The rest time is set according to the appropriate time or number of operations (opening and closing) selected according to the lubrication condition of each lubrication point.

(10) Start the host into working state, the timer will work in a loop according to the set time.

VII、Maintenance

1. To ensure the proper operation of your mechanical and lubrication systems, be sure to use clean 30cSt-250cSt lubricant and keep it clean.

2. The oil pipe and the filter screen at the oil suction port must be checked and cleaned every month to prevent the filter screen at the oil suction port from being blocked, resulting in reduced pumping capacity or insufficient pressure

3. When starting the main engine every day, it is necessary to check whether the lubrication system circulates oil according to the set cycle. If the time control system fails and the motor does not stop running, the abnormality should be eliminated immediately to prevent the motor from being burned out or even causing serious losses.

4. After the injection machine is powered on, do not open the top shell to prevent electric shock and fire accidents.



VIII、Common faults and troubleshooting methods

S/N	Faults	Cause of faults	Troubleshooting
1	Dead motor	The voltage used is not correct	Apply correct voltage
		wiring error	Connect wires in the right way
		Suction fine sand stuck pump	Remove the bottom gear pump for cleaning (this must be operated by professionals)
2	Insufficient pressure	Pressure gauge damaged	Change the pressure gauge
		Main oil pipe leakage	Check the main oil pipe and eliminate oil leakage
		When pressure is applied, a branch oil pipe is severely leaking	Check and replace the oil outlet branch
		Sealing of lubricator overflow valve is not good	Remove and clean
		Oil suction port is blocked	Clean the oil tank and filter screen at the oil suction port
3	No oil leak	Air is not drained out of the pump	Repeat the oil pump, and loosen the main outlet if necessary
		Dead motor	See S/N 1
4	Little oil leak	Oil suction port is blocked	Clean the filter screen at the oil suction port
		Sealing of lubricator overflow valve is not good	Remove and clean
5	Pressure switch failure	Insufficient system pressure	Check the pipeline pressure, the volume must reach 12kg/cm ² resistance must reach 10kg/cm ²
		Wrong wiring	Connect it in the correct way
6	Dead motor of digital display Lubrication pump	The motor wiring is loose or the motor is damaged	Reconnect and replace the motor



宝腾智能润滑技术(东莞)有限公司

BAOTN INTELLIGENT LUBRICATION TECHNOLOGY (DONGGUAN) CO.,LTD.

宝腾智能润滑技术(东莞)有限公司

BAOTN INTELLIGENT LUBRICATION TECHNOLOGY (DONGGUAN) CO.LTD.

总部地址:广东省东莞市松山湖园区南山路 40-3 号

ADD: Building No 40-3, Nanshan Road, Songshan Lake Park,

Dongguan City, Guangdong Province

华东工厂:南京市溧水区经济开发区南区水保路 1 号

East China Factory: No. 1, Shuibao Road, South District, Economic Development Zone, Lishui District, Nanjing

华南工厂:东莞市大岭山汇鑫工业园 2 栋

South China Factory: Building 2, Huixin Industrial Park, Dalingshan, Dongguan City

总机(Switchboard):0769-88697068

传真(Fax):0769-88697067

Sales Manager: Candy Luo

Phone number:+86 18822972886

E-mail: 6687@baotn.com

www.baotn.com.cn

全国服务热线: 400-880-8722

注:本畫册内說明文字、圖樣及技術參數隨技術發展而更改,恕不另行通知。

Note: The words, designs and technical parameters are subject to change along with the development of technologies without prior notice.



企业官网



微信公众号

代理商 (Agent):