



使用说明书

BTA 间歇性电动油稀油滑泵

集中潤滑給油裝置

**CENTRALIZED
LUBRICATION
DEVICE**



专注减磨增效，成就客户核心竞争力

宝腾智能润滑技术(东莞)有限公司

BAOTN INTELLIGENT LUBRICATION TECHNOLOGY (DONGGUAN) CO.,LTD.





Directory

I、 Safety Instructions	1
II、 Declaration	1
III、 Overview	2
IV、 Overall and installation Dimensions	2
V、 Lubrication Pump Selection & Technical Specifications	3
VI、 Electrical Wiring Diagram and Use of Panel	4
VII、 Instructions and Precautions	5
VIII、 Troubleshooting and Solutions	8

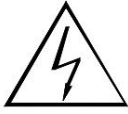

I、 Safety Instructions

The following symbols provide important safety guidelines for proper product usage.	
	Read the product manual carefully before operation. Improper use may cause equipment damage or personal injury.
	Always disconnect power before performing maintenance or repairs.
	Ensure proper grounding during wiring. Incorrect grounding may cause severe damage
	Warning

II、 Declaration

All components are manufactured in compliance with occupational safety and accident prevention regulations. However, improper use may still pose risks to users, third parties, or property. Therefore, strictly follow the operating instructions. Any safety-related issues must be addressed immediately.

+ Disclaimer

Dongguan Baoteng is not liable for damages caused by:

Insufficient lubricant

Use of solid or incompatible lubricants

Improper usage

Installation or connection errors

Incorrect troubleshooting

+ Authorized Installation Technicians

Only certified engineers may install, operate, maintain, or repair this product. Certified personnel must be trained, experienced, and knowledgeable about relevant standards, regulations, and safety protocols.

+ Transport & Storage

No restrictions apply for road, air, or sea transport.

+ Environmental Protection

Oil and grease are hazardous to soil and water. Follow special safety regulations for storage, handling, and transportation.

III、 Overview

The BTA type light oil electric lubricating pump is specially designed and manufactured to support various small and medium-sized machinery. It is very economical and practical, suitable for CNC machines, machining centers, production lines, textile, plastics, printing, chemical, woodworking, food, and other machinery industries, ensuring the lubrication performance of all kinds of machinery products and extending the service life and precision of mechanical equipment.

The BTA type light oil and grease electric lubricating pump can be combined with a metered volumetric distributor to form a volumetric lubrication system for precise lubrication of lubrication points. Especially when used together with the BFA and BFD type metered volumetric distributors produced by our company, it can fully enhance the lubrication effect. It can also be combined with BSA, BSB, BSC, GSA, and other types of proportional joints to form a resistance (damping) lubrication system, providing proportional lubrication to lubrication points.

IV、 Lubrication Pump Dimensions & Working Principle

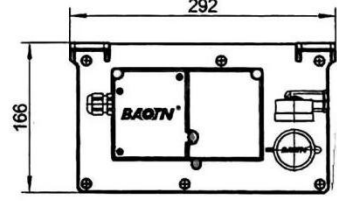
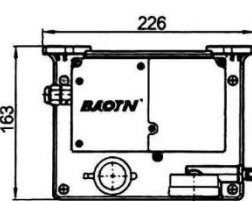
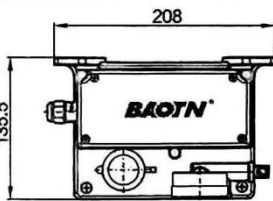
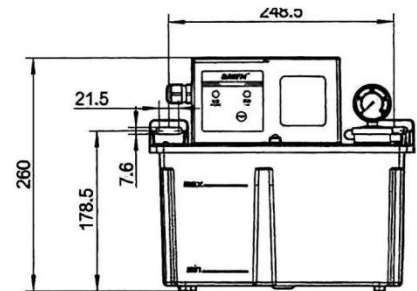
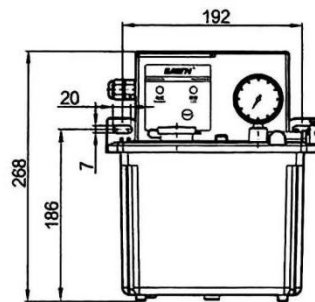
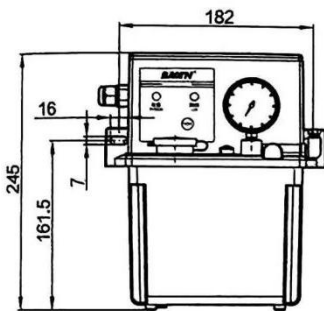

2L

3L

4L(Resin oil tank)

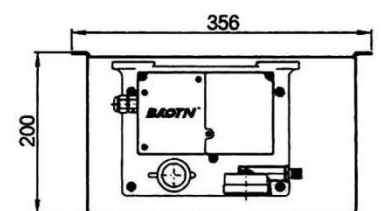
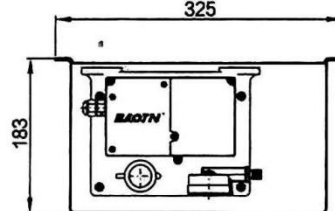
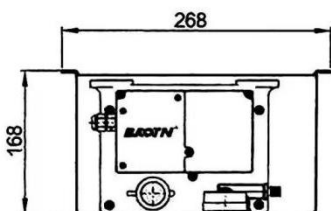
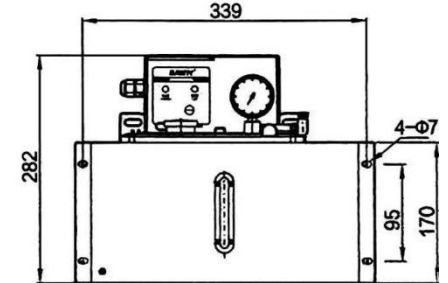
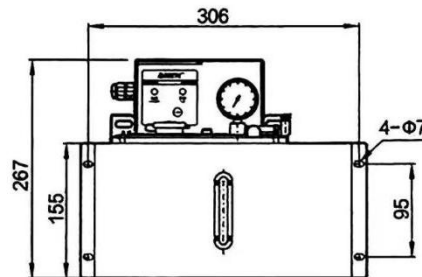
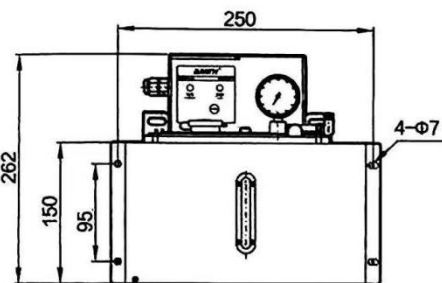

4L (Sheet metal oil tank)

6L

8L

V、Lubrication Pump Selection & Technical Specifications

BTA-A2

Pressure switch

P	Pressure switch
Blank	None

oil tank volume

2	2L
3	3L
4	4L
6	6L
8	8L

voltage type

1	110VAC,50/60Hz
2	220VAC,50/60Hz
9	24VDC

oil tank

Blank	Resin oil tank
A	Metal oil tank without oil return device

Liquid level switch

W	Without level monitor
Blank	with level monitor

Outlet pipe diameter

6	Connected to φ6 pipe
---	----------------------

Throughout

2	200mL/min
5	150mL/min

BTA-C2

Pressure switch

P	Pressure switch
Blank	None

oil tank volume

2	2L
3	3L
4	4L
6	6L
8	8L

voltage type

1	110VAC,50/60Hz
2	220VAC,50/60Hz
9	24VDC

oil tank

Blank	Resin oil tank
A	Metal oil tank without oil return device

Liquid level switch

D	Normal Close
Blank	Normal Open

Outlet pipe diameter

6	Connected to φ6 pipe
---	----------------------

Throughout

2	200mL/min
5	150mL/min

Thin oil lubrication pump with digital display(Volumetric type)

PLC control thin oil lubrication pimp(Volumetric type)

BTA-A1

Pressure switch

P	Pressure switch
Blank	None

oil tank volume

2	2L
3	3L
4	4L
6	6L
8	8L

voltage type

1	110VAC,50/60Hz
2	220VAC,50/60Hz

oil tank

Blank	Resin oil tank
A	Metal oil tank without oil return device

Liquid level switch

W	Without level monitor
Blank	with level monitor

Outlet pipe diameter

6	Connected to φ6 pipe
---	----------------------

Throughout

2	200mL/min
5	150mL/min

BTA-C1

Pressure switch

P	Pressure switch
Blank	None

oil tank volume

2	2L
3	3L
4	4L
6	6L
8	8L

voltage type

1	110VAC,50/60Hz
2	220VAC,50/60Hz

oil tank

Blank	Resin oil tank
A	Metal oil tank without oil return device

Liquid level switch

D	Normal Close
Blank	Normal Open

Outlet pipe diameter

6	Connected to φ6 pipe
---	----------------------

Throughout

2	200mL/min
5	150mL/min

Thin oil lubrication pump with digital display(Resistance-type)

PLC control thin oil lubrication pimp(Resistance-type)

System Type:

- 1: Indicates resistive type (without a pressure relief device, used with a resistive distributor)
- 2: Indicates volumetric type (with a pressure relief device, used with a volumetric distributor)

Control Type:

- A: Digital display microcomputer controller
- C: Indicates external PLC control

type	Voltage (V)	Power (W)	Rated pressure (MPa)	Maximum Output pressure (MPa)	Throughout (mL/min)	Oil tank volume (L)	Oil viscosity (cSt)
BTA-A2	110VAC 220VAC 24VDC	20	1.5	2.5	150 200	2	32~220
BTA-C2			1.5	2.5		3	
BTA-A1	110VAC 220VAC		1	2.5	200	4	
BTA-C1			1	2.5		6	
						8	

VI、Electrcial Wiring Diagram and Use of Pancel

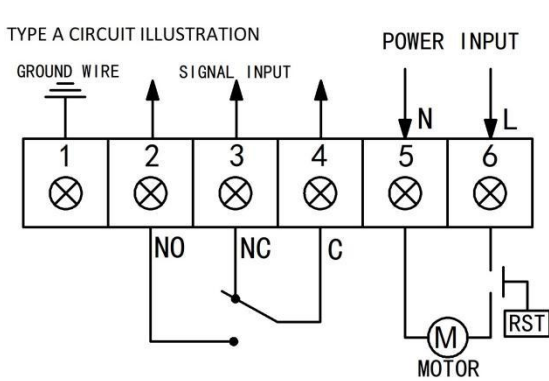

A-type circuit wiring diagram

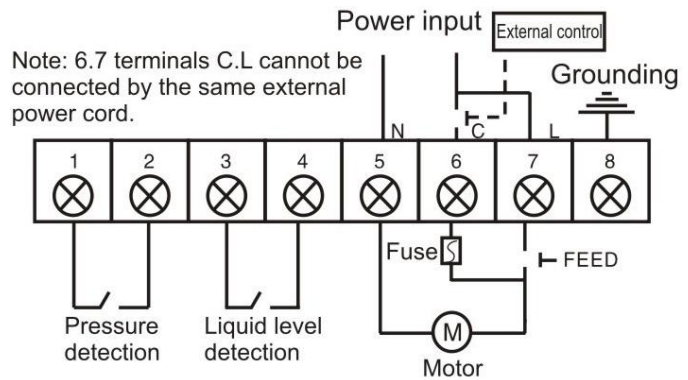

C-type circuit wiring diagram

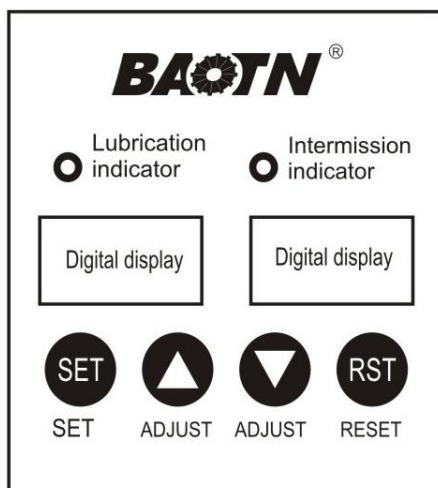

Description of A-type panel

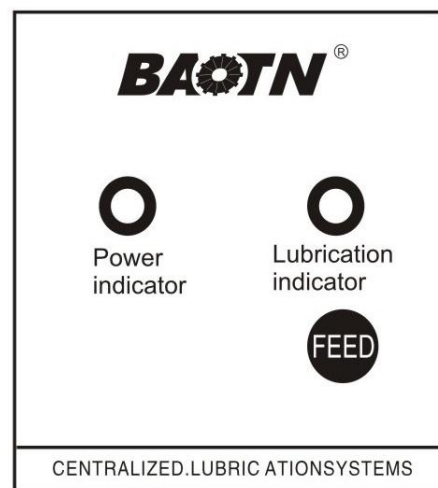

Description of R-type panel



VII、 Instructions and Precautions

1. Performance Characteristics of BTA

- ① The positive displacement lubrication pump is equipped with a pressure relief device and must be used with positive displacement distributors such as BFA/BFB/BFD/BFE/BFG/BFH;
- ② The resistance-type lubrication pump has no pressure relief device and must be used with resistance-type distributors such as BSA/BSB/BSE/BSF/BSG/BSH;
- ③ Lubrication time setting: Must be longer than the time required for the pressure gauge to reach the rated pressure;
Interval time setting: Select an appropriate interval time based on the lubrication condition of each lubrication point (single lubrication time $\leq 120s$, and the interval time is typically more than 5 times the lubrication time) to prevent motor thermal protection;
- ④ When the system triggers a fault alarm, press the reset key (RST) to restart operation after troubleshooting.

2. Operating Instructions for Type A Digital Display Oil Lubrication Pump

(1) Performance and Characteristics

- ① The system can be set to three operating modes:
 - a. Lubrication: Starts timing the lubrication period upon startup;
 - b. Interval: Starts timing the interval period after lubrication is completed;
 - c. Memory: Resumes the remaining interval time from the previous cycle after a power failure and restoration;
- ② Lubrication and interval times can be customized within the following ranges (a lock function is included to secure the set values):
 - LUB Lubrication time: 1~999 S (seconds);
 - INT Intermittent time: 1~999 Min (minutes);
 - ※ Recommendation: Set the interval time to be more than 5 times the lubrication time.
- ③ The Type A digital display controller triggers an alarm under the following conditions, with the digital tube flashing and a buzzer sounding:
 - a. Displays "Erp" for insufficient pressure;
 - b. Displays "Ero" for insufficient fluid level;
- ④ The panel indicator lights can show the lubrication and intermittent status of the system;
- ⑤ Pressing the "RST" key in any state can force lubrication or clear an alarm signal.

(2) Usage Instructions

- ① Install the lubrication system correctly with the corresponding distributors and pipelines;
- ② Ensure the input power matches the pump's operating voltage. Connect and secure the power wires according to the circuit diagram;
- ③ Confirm that the pump body is grounded or connected to neutral to prevent electric shock or fire accidents;
- ④ The factory-set working pressure for positive displacement pumps is 1.5MPa and 1MPa for resistance-type pumps. Do not adjust the pressure without authorization;
- ⑤ Recommended oil: ISO VG 32-220cSt lubricating oil. Do not use lubricants containing impurities;
- ⑥ Setting the lubrication time, The factory default lubrication time is 20s, and the interval time is 3min. To adjust the time, follow these steps:

Press and hold the SET key for 2 seconds. The left digit on the digital display will flash, indicating entry into the lubrication time setting mode (default unit: seconds). Press the SET key briefly to toggle flashing between the units, tens, and hundreds digits. Use the increase (up arrow) or decrease (down arrow) keys to adjust to the desired lubrication time;

Press and hold the SET key for 2 seconds again to enter the interval time setting mode (default unit: minutes). The right digit on the display will flash. Press the SET key briefly to toggle flashing between the units, tens, and hundreds digits. Use the increase or decrease keys to adjust to the desired interval time;

Press and hold the SET key for 2 seconds once more to save the settings to memory. The digital tube will display the modified lubrication and interval times, and the system will automatically start operating with the new settings;

- ⑦ Before connecting the main oil pipe, run the pump unloaded to expel air from the pump body. After air is expelled, connect the main oil pipe. Open the plug at the end of the system and add oil to expel air from the main oil pipe. Inspect the pipelines to ensure there are no leaks. Add oil until each lubrication point discharges oil;

(3)Precautions

※ During the initial oil filling to the distributor on the main oil pipe, the process may take a longer time. Press the "RST" key repeatedly to continue oil filling until the pressure gauge reaches the rated pressure value . Simultaneously, inspect and ensure there is no oil leakage from the main oil pipe. Continue filling until oil is discharged from all lubrication points. If the buzzer alarms during operation, it may be due to detected insufficient pressure and is not a malfunction. Press the "RST" key to clear the abnormal alarm signal.

3. Type C PLC-Controlled Oil Lubrication Pump

(1) Performance Characteristics

- ①Equipped with a liquid level switch and a pressure switch (optional).An abnormal signal is output when oil volume or pressure is insufficient;
- ②The panel indicator lights display the power and lubrication status of the lubrication pump;
- ③The system includes a "FEED" key for forced lubrication;
- ④The motor features self-protection functions to prevent overheating and overload;
- ⑤An internal fuse is provided to prevent short circuits from causing excessive current that could damage the IC board and motor.

(2)Usage Instructions

- ①Install the lubrication system together with the corresponding distributor and pipeline;
- ②Ensure the input power matches the pump's operating voltage. Connect and secure the power wires according to the circuit diagram;
- ③Confirm that the pump body is grounded or connected to neutral to prevent electric shock or fire accidents;
- ④The factory-set working pressure for positive displacement pumps is 1.5MPa and 1MPa for resistance-type pumps. Do not adjust the pressure without authorization;
- ⑤Recommended oil: ISO VG 32-220cSt lubricating oil. Do not use lubricants containing impurities;
- ⑥The oil supply time of the electric lubrication pump is controlled by an external PLC;
- ⑦ Before connecting the main oil pipe, run the pump unloaded to expel air from the pump body. After air is expelled, connect the main oil pipe. Open the plug at the end of the system and add oil to expel air from the main oil pipe. Inspect the pipelines to ensure there are no leaks. Add oil until each lubrication point discharges oil.

(2)Precautions

- ※ For Type C electric lubrication pumps equipped with optional pressure switches, the external PLC programming should incorporate an insufficient pressure alarm function. Specifically, if the lubrication pump operates for an extended period while the pressure remains below the activation pressure of the pressure switch, the system should be considered abnormal. An alarm signal must then be triggered, and the lubrication pump should be immediately stopped for inspection and repair.
- ※ During the initial oil filling to the distributor on the main oil pipe, the process may take a longer time. Press the "RST" key repeatedly to continue oil filling until the pressure gauge reaches the rated pressure value . Simultaneously, inspect and ensure there is no oil leakage from the main oil pipe. Continue filling until oil is discharged from all lubrication points. If the buzzer alarms during operation, it may be due to detected insufficient pressure and is not a malfunction. Press the "RST" key to clear the abnormal alarm signal.

4. Usage and Instructions for Key Components

(1) Pressure Switch

The activation pressure of the pressure switch is the same as the operating pressure of the distributor. The pressure switch serves two main functions:

- ① For Type C electric lubrication pumps, the connection status of the pressure switch can determine whether the working pressure of the lubrication system has reached the oil discharge pressure of the distributor. It outputs a signal to the external PLC accordingly;
- ② For Type A electric lubrication pumps, the pressure switch detects insufficient pressure and triggers an alarm. Specifically, it provides a signal to the microcomputer controller by monitoring the system pressure. If the pressure does not reach the activation threshold, the system stops operation and triggers an alarm. However, the system allows an extension of approximately 15 seconds to enable the system pressure to reach the rated pressure. This ensures sufficient time for the quantitative oil cylinder in the distributor to accumulate oil, guaranteeing accurate oil delivery.

(2) Pressure Regulating Valve

If the system pressure is lower than the rated pressure, the lubrication time should be extended or the relief valve should be adjusted (must be performed by professionals). The specific adjustment steps are as follows:

- A. Disconnect the power supply to the lubrication pump and remove the oil tank;
- B. Loosen the lock nut counterclockwise, then tighten the adjustment screw clockwise to an appropriate position to compress the spring (it is recommended to adjust by half a turn at a time);
- C. Tighten the lock nut clockwise, then reinstall the oil tank and connect the main oil pipe;
- D. Restore the power supply and check whether the lubrication pump reaches the rated pressure. If the rated pressure is not achieved, repeat the above steps.

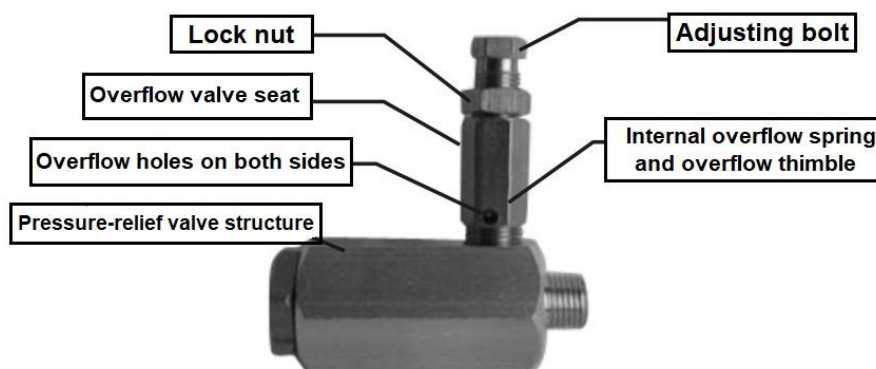



VIII、 Troubleshooting and Solutions

S/N	Faults	Cause of faults	Troubleshooting
1	Motor does not start	Improper working voltage	Apply correct voltage
		Wrong wiring	Connect wires in the right way
		Gear pump jammed due to fine sand particles	The bottom gear pump must be removed for cleaning by a professional person
		Wires connecting the motor and control pane get loosened or motor heats up and stops automatically	When motor temperature drops to normal, the motor will recover on its own .It is suggested to adjust the lubrication time below 2 min and intermission time above 5 times of lubrication time
2	Insufficient pressure	Pressure gauge damaged	Replace the pressure gauge
		Main oil pipe leakage	Inspect the main oil pipe and eliminate any leakage
		Severe oil discharge from a branch pipe during pressurization	Check and replace the leaking branch pipe
		Sealing of lubricator overflow valve is not good	Remove for cleaning
		Oil suction port is blocked	Clean the oil tank and filter screen at the suction port
3	NO oil output	Air is not drained out of the pump	Repeat the oil priming process. If necessary, loosen the outlet port before priming
		Motor does not start	See S/N 1
4	Insufficient oil output	Oil suction port is blocked	Clean the filter screen at the suction port
		Sealing of lubricator overflow valve is not good	Remove for cleaning
5	Pressure Switch failure	Insufficient system pressure	Check the pipeline pressure. It must reach the rated pressure.
		Wrong wiring	Re-wire according to the correct wiring diagram.



以客户为中心 · 以奋斗者为本



宝腾智能润滑技术(东莞)有限公司

BAOTN INTELLIGENT LUBRICATION TECHNOLOGY (DONGGUAN) CO.,LTD.

宝腾智能润滑技术(东莞)有限公司

BAOTN INTELLIGENT LUBRICATION TECHNOLOGY (DONGGUAN) CO.LTD.

总部地址:广东省东莞市松山湖园区南山路 40-3 号

ADD: Building No 40-3, Nanshan Road, Songshan Lake Park,

Dongguan City, Guangdong Province

华东工厂:南京市溧水区经济开发区南区水保路 1 号

East China Factory: No. 1, Shuibao Road, South District, Economic Development Zone, Lishui District, Nanjing

华南工厂:东莞市大岭山汇鑫工业园 2 栋

South China Factory: Building 2, Huixin Industrial Park, Dalingshan, Dongguan City

总机(Switchboard):0769-88697068

传真(Fax):0769-88697067

Sales Manager: Candy Luo

Phone number:+86 18822972886

E-mail: 6687@baotn.com

www.baotn.com.cn

全国服务热线: 400-880-8722

注:本畫册内說明文字、圖樣及技術參數隨技術發展而更改,恕不另行通知。

Note: The words, designs and technical parameters are subject to change along with the development of technologies without prior notice.



企业官网



微信公众号

代理商 (Agent):